

**Adipokine Responses to Exercise Repeated on Successive Days in Men with Metabolic Syndrome**

by

Felipe Araya-Ramírez

A dissertation submitted to the Graduate Faculty of  
Auburn University  
in partial fulfillment of the  
requirements for the Degree of  
Doctor of Philosophy

Auburn, Alabama  
December 13, 2010

Exercise Physiology

Copyright 2010 by Felipe Araya-Ramírez

Approved by

Peter W. Grandjean, Chair, Associate Professor of Kinesiology  
Daniel Blessing, Associate Professor of Kinesiology  
Lawrence C. Wit, Professor of Biological Sciences  
Margaret E. Ross, Associate Professor of Educational Foundations Leadership and Technology

## Abstract

Leptin and adiponectin are two insulin-sensitizing adipokines that may be influenced transiently by exercise and contribute to the post-exercise improvement in insulin-mediated glucose uptake. The influence of exercise on these adipokines is inconsistent and confounded by a variety of factors. Therefore, the purpose of this study was to characterize the temporal responses of adipokines to repeated exercise bouts in successive days in obese males with metabolic syndrome and their relationship with markers of insulin resistance. Exercise sessions were completed by expending 350 kcals of energy, walking on a treadmill at 60 to 70% of  $\dot{V}O_{2\max}$ , on each of four successive days. Blood samples from eleven middle-aged men (Age:  $50 \pm 8.0$  years, BMI =  $32.0 \pm 4.6$  kg/m<sup>2</sup>, % Fat =  $29 \pm 4.0$  (% of body weight),  $\dot{V}O_{2\max}$  =  $28.9 \pm 4.3$  ml·kg<sup>-1</sup>·min<sup>-1</sup>, SBP =  $140 \pm 8.6$  mmHg, DBP =  $92 \pm 6.3$  mmHg, triglyceride =  $267 \pm 145.0$  mg/dL, HDL-C =  $32 \pm 5.0$  mg/dL, glucose =  $99.6 \pm 12.8$  mg/dL) were obtained before each exercise session and obtained again at 24 and 72 hours after the last exercise bout. Changes in plasma volume-adjusted total and HMW adiponectin, leptin, NEFA, glucose and insulin were determined using multiple 1 x 6 repeated-measures ANOVAs. Insulin concentrations decreased 26% with a single bout of exercise. Leptin decreased 9% after two exercise sessions and remained lower up to 24 hours following the last exercise session. NEFA, glucose, the HOMA score, adiponectin and HMW adiponectin remained unaltered with exercise. The accumulated effect of multiple bouts of exercise in leptin concentrations was greater than the effect obtained from two exercise bouts but not related to changes in insulin concentrations or the HOMA score. Leptin changes following exercise may contribute to lower insulin resistance following exercise but is not necessary for the reduced insulin resistance observed after exercise.

## Acknowledgments

I would like to express my extreme gratitude and appreciation to Dr. Peter Grandjean as my advisor and friend for guiding me and helping me to improve my professional career throughout all these years during my doctoral work. I would like to thank the members of my doctoral committee, Dr. Margaret Ross, Dr. Daniel Blessing and Dr. Lawrence Wit, for their time, support and constructive comments for this project. I would like to thank Dr. Eric Plaisance, Mr. Kyle Taylor, and Dr. Robert Bowers for their time and efforts in the analysis of biochemical data for this dissertation. I would like to thank Dr. Jack Mahurin for the medical screening of the participants in this study. I also would like to thank Dr. Mary Rudisill, Dr. José Moncada and Dr. John Quindry for their friendship, support and advice throughout this project. I would like to thank my father, my mother and my brothers and sisters, as well as my in-laws, for their full support.

Most importantly, I am tremendously grateful to my lovely wife and my two beautiful sons for their love and patience throughout these five and half years. I appreciate their support and understanding for the time spent away from them to complete my doctoral program.

## Table of Contents

Abstract .....	ii
Acknowledgments .....	iii
List of Tables .....	vi
List of Figures .....	vii
Introduction .....	1
Body Weight, Adipose Tissue and Metabolic Health .....	1
Adiponectin, Leptin and Aerobic Exercise Training .....	3
Adiponectin, Leptin and Transient Responses to Exercise.....	4
Rationale for the Investigation.....	6
Hypotheses and Rationale.....	7
Assumptions.....	11
Delimitations.....	11
Limitations .....	11
Significance of the Study .....	12
Review of Literature .....	13
Metabolic Syndrome, Insulin Resistance and Metabolic Health .....	13
Exercise, Glucose Uptake and Insulin Sensitivity .....	16
Role of Adipose Tissue on Metabolic Health.....	21
Physical Activity, Aerobic Exercise and Adipokines.....	27
Acute Adipokine Responses to Exercise .....	36

Factors that Influence Adipokine Responses to Exercise .....	43
Summary .....	45
Methods .....	46
Overview.....	46
Participants.....	47
Blood Sampling Procedures.....	47
Biochemical Analysis .....	47
Statistical Analysis.....	48
Results .....	49
Baseline Physiological Characteristics .....	49
Clinical Markers of Insulin Sensitivity (unadjusted for plasma volume changes) .....	50
Adipokine Concentrations (unadjusted for plasma volume changes).....	51
Clinical Markers of Insulin Sensitivity (adjusted for plasma volume changes) .....	52
Adipokine Concentrations (adjusted for plasma volume changes).....	53
Physiological Responses to Exercise.....	53
Correlations.....	54
Quality Control .....	54
Discussion .....	55
Adipokines Responses to a Single Bout of Exercise .....	56
Adipokines Responses to Repeated Exercise .....	58
Accumulated Effect of Multiple Bouts of Exercise.....	60
Summary and Conclusions .....	61
References .....	63

## List of Tables

Table 1. Clinical Criteria for the Diagnosis of Metabolic Syndrome .....	14
Table 2. Concentrations of Adiponectin in Different Populations .....	22
Table 3. Effect of Exercise Training on Adiponectin .....	34
Table 4. Effect of Exercise Training on Leptin .....	37
Table 5. Effect of Acute Exercise on Adiponectin .....	40
Table 6. Effect of Acute Exercise on Leptin.....	43
Table 7. Baseline Physiological Characteristics .....	49
Table 8. Participants Meeting Criteria for Metabolic Syndrome .....	50
Table 9. Clinical Markers of Insulin Sensitivity (unadjusted for plasma volume changes): Responses to Exercise and Recovery.....	51
Table 10. Adiponectin Concentrations (unadjusted for plasma volume changes).....	51
Table 11. Clinical Markers of Insulin Sensitivity (adjusted for plasma volume changes).....	52
Table 12. Adiponectin Concentrations (adjusted for plasma volume changes).....	53
Table 13. Exercise Session Characteristics.....	53

## List of Figures

Figure 1. Proposed Model for Exercise and Insulin Sensitivity .....	18
Figure 2. Schematic of the Experimental Protocol .....	46
Figure 3. Plasma Volume-unadjusted and Adjusted Leptin Responses to Exercise.....	52

## **CHAPTER I**

### **INTRODUCTION**

#### **Body Weight, Adipose Tissue and Metabolic Health**

Recent estimates indicate 55 million Americans exhibit characteristics of metabolic syndrome (MetS), (30) a group of metabolic risk factors that include abdominal obesity, insulin-resistance, dyslipidemia, hypertension, pro-thrombotic and pro-inflammatory states (40, 96). Individuals with these metabolic risk factors are at increased risk of cardiovascular disease (17, 76) and type 2 diabetes mellitus (45, 86).

Specific adipose deposits – rather than total obesity – appear to greatly influence the development of MetS (130). Excess accumulation of abdominal visceral fat and ectopic fat – fat in the liver, skeletal muscle and pancreatic beta cells – are implicated in lipotoxicity, insulin resistance, and an elevated low-grade inflammatory-immune response (39, 91, 115).

Adipose tissue synthesizes and secretes a group of known proteins called “adipokines” that have several functions including regulation of appetite, energy expenditure, glucose and lipid metabolism, insulin sensitivity, inflammation and vascular regulation (57, 67, 82, 114, 115, 145). Two well-studied adipokines implicated as major insulin-sensitizing agents are leptin (88) and adiponectin (118)

Leptin can regulate energy intake by acting on receptors in the hypothalamus of the brain where it inhibits appetite (11, 48). Leptin increases energy expenditure by increasing the sympathetic nervous system activity and stimulating insulin-mediated glucose uptake via activation of adenosine monophosphate kinase (AMPK) (11). Increased leptin concentrations



occur with body fat accumulation and metabolic dysfunction and are thought to be due to a systemic “leptin resistance” (117). Indeed, higher concentrations of leptin have been directly correlated with the degree of obesity (88) and with MetS independent from obesity (31), where leptin concentrations are elevated and leptin transporters and receptors are impaired (5). The chronically-elevated leptin concentrations stimulate a pro-inflammatory response by increasing the macrophage production of tumor necrosis factor alpha (TNF- $\alpha$ ) and interleukin-6 (IL-6). These cytokines are implicated in inflammation, insulin resistance, and atherosclerosis (6, 84). Leptin concentrations decrease with weight loss in obese individuals (50, 114, 116). The lowering of blood leptin concentrations that occur with weight loss may be reflective of an enhanced target tissue sensitivity (106). Thus, the actions of leptin in healthy tissues are to coordinate peripheral and central signals of appetite and metabolism. However, leptin may be influenced by - and contribute to -metabolic dysfunction due to chronic energy imbalance favoring weight gain (83).

As with leptin, adiponectin enhances glucose and lipid metabolism in the skeletal muscle by activating the AMPK system (11, 13). Adiponectin increases insulin sensitivity in skeletal muscle, liver, pancreas, and adipose tissue (140). The exact mechanism by which adiponectin improves insulin sensitivity is not fully understood. Adiponectin may heighten insulin sensitivity by directly stimulating tyrosine phosphorylation of the insulin receptor and/or facilitate glut-4 transporters to the cell surface via enhanced AMPK-mediated fatty acid oxidation (11, 140). In addition to regulating glucose and lipid oxidation, adiponectin has anti-atherogenic, anti-inflammatory (82, 89, 102), and anti-cancer effects (66, 146). Adiponectin expression and plasma concentrations are reduced in obese individuals and type 2 diabetics (50, 54, 135). However, circulating adiponectin concentrations increase after weight loss (56, 71, 101, 116) and may be a major factor in the improved insulin sensitivity observed after weight reduction (101).

Adiponectin circulates in plasma in several oligomeric forms. Three primary forms are low molecular weight (LMW), medium molecular weight (MMW) and high molecular weight (HMW) adiponectin (65, 133, 146). These oligomers appear to coordinate different tissue effects via tissue-specific adiponectin receptors (65, 127). For example, the liver and skeletal muscle are more responsive to HMW adiponectin versus the other two forms (133). Therefore, some have suggested that HMW adiponectin is a better indicator of insulin sensitivity than total adiponectin concentrations because of the insulin sensitizing effect of HMW in these tissues and the fact that over 80% of insulin-mediated glucose uptake occurs in the liver and skeletal muscle (70, 80).

### **Adiponectin, Leptin and Aerobic Exercise Training**

The influences of exercise training in total and HMW adiponectin concentrations are poorly characterized. Exercise training appears to increase total adiponectin concentration in some cases (9, 53, 74, 101, 112) but not always (10, 56, 63, 95, 99, 108, 116, 142). There does not appear to be a common type, volume, or intensity of exercise that systematically alters total or HMW adiponectin concentrations. The exercise programs in these studies were of short to long duration, the volume was from 100 to 480 minutes per week, the intensity was low to moderate, and the modes of exercise were walking, running, cycling, rowing and swimming (10, 53, 56, 63, 74, 99, 101, 108, 112, 116, 142). Factors other than the exercise characteristics may contribute to the inconsistent results. Only two researchers reported the timing of the blood sample after the last bout of exercise when total adiponectin increased after exercise training (9, 74). Kriketos et al. (74) measured adiponectin concentrations at 24 to 36 hours after the last bout of exercise.

Blüher et al. (9) measured adiponectin 48 hrs after the last training session of exercise. Others have measured adiponectin concentrations during or immediately after exercising (53, 112). In addition, it is unclear whether adiponectin concentrations were corrected for plasma volume

shifts that are known to exist for several days after the exercise and may influence the interpretation of results (121). By measuring blood variables within a few days of the last bout of exercise and not correcting for plasma volume fluctuations with exercise training, the reported adaptations may have been confounded by dilutions due to intra-vascular fluid shifts and transient responses to the last session of exercise.

In general, leptin concentrations do not change after exercise training in sedentary lean young or adult subjects or in sedentary older overweight individuals except when body weight or body fat are reduced (51, 125). Pasma et al. (106) reported that leptin concentrations decreased in middle-aged obese males after long-term exercise training that included running, cycling, and swimming at low-to moderate-intensity. The decrease in leptin was independent of changes in body fat or insulin concentrations. However, the change in body fat reported in the training group seems to be important in the reduction in leptin concentrations because the change in the percentage of body fat and the change in insulin concentrations explained 44% of the variation observed in the leptin response. In order to evaluate the influence of diet and exercise on adipokine responses to weight loss, Reseland and colleagues (110) reported that leptin concentrations decreased by 4% after one-year of aerobic training in men with metabolic syndrome. The diet group in this study decreased leptin by 8% and the combined exercise and diet group decreased leptin by 24%. Because the magnitude of fat loss was also greater in the exercise plus diet group, the change in fat mass reported in all groups was thought to have had a greater effect on the reduction of leptin concentrations than the interventions used to induce the weight loss.

### **Adiponectin, Leptin and Transient Responses to Exercise**

There is evidence that adiponectin may be transiently altered with exercise. Jürimäe and colleagues (64) reported that elite rowers, performing a 6000-meter time-trial, decreased total

adiponectin concentrations by 11% in response to the single exercise session. The same investigators (63) reported a 12% increase in adiponectin after a maximal bout of rowing exercise in elite athletes. In addition, Kriketos et al. (74) reported a 260% increase in adiponectin in overweight individuals after two to three 40-minute bouts of walking / jogging at 55-70% of  $\dot{V}O_{2max}$  over a one-week period.

Total and HMW adiponectin concentrations, however, do not consistently respond to a single exercise session (26, 59, 72, 98, 109, 142). Similar to the exercise training literature, the studies (26, 59, 72, 98, 109, 142) where total and HMW adiponectin remained unchanged in the hours and days after a single exercise session vary in design. Participants included athletes, healthy sedentary, lean, overweight, and obese. Exercise time ranged from 30 to 120 minutes per session, intensity ranged from 50 to 90% of their maximal aerobic capacity, and the modes of exercise included running on a treadmill or cycling on a cycle ergometer. The timing of the blood sampling reported in some studies (26, 59, 72, 74) was immediately after the exercise (26), 30 minutes (72), 24, and 48 (59) hours after the exercise bout. Occasionally, blood variables were corrected for post-exercise plasma volume shifts (26, 59, 64, 72).

Although leptin concentrations frequently do not change after exercise lasting less than 60 minutes (26, 75, 126, 134), exercise resulting in significant caloric expenditure or of high-intensity may be necessary for inducing a leptin response (11). Elias et al. (22) and Jürimäe et al. (62) observed that leptin concentrations decreased up to 15% after maximal treadmill exercise in middle-aged men. Essig and colleagues (23) reported a delayed decrease in plasma volume-corrected leptin 48 hours after long-term exercise in which participants expended 800 and 1500 kcal running on a treadmill, suggesting that there may be a delayed response in leptin concentrations after exercise. In contrast, Ferguson and colleagues (26) found that a single bout

of exercise for 60-minutes at moderate-intensity in young healthy men and women did not alter leptin concentrations.

### **Rationale for the Investigation**

The accumulation of excess body fat is generally reflective of an energy imbalance where energy intake chronically exceeds energy expenditure (93). This excess accumulation of fat, and particular visceral fat, is linked with individuals with symptoms of underlying metabolic dysfunction such as insulin resistance, impaired fasting glucose, dyslipidemia, inflammation and hypertension (18). The interest in studying the effects of exercise training on adipokine responses is that physical exertion increases caloric expenditure and; thereby, reduces or reverses the discrepancy between caloric intake and caloric expenditure (93). Physical health is improved in many ways with weight loss. However, the well-documented improvements in cardiovascular and metabolic health that occur with regular exercise are, in large part, independent of weight loss and may be partly attributed to adipokine-mediated mechanisms (132).

Many adipokines and cytokines are known as acute-phase reactants. They are released into tissues and the circulation in rapid response to metabolic changes (115). Leptin and adiponectin are adipokines that act as insulin-sensitizing agents in adipose tissue and skeletal muscle and may partially mediate the improved insulin sensitivity observed after moderate-intensity exercise (11, 140). This may be especially true in deconditioned or sedentary obese individuals and those exhibiting metabolic dysfunction, such as MetS and type 2 diabetes (10, 26, 27, 59). Thus, it stands to reason that single episodes of exercise, of sufficient intensity and energy expenditure, may induce an adipokine and insulin response that may previously have been attributed to exercise training. However, the limited and equivocal evidence to support this position may be because of tremendous variation in experimental design and methodology employed to explore this line of inquiry. For example, the exercise stimuli varies with respect to

the participants' health and fitness status, the timing of blood samples – relative to the last bout of exercise – and whether or not adipokine concentrations in post-exercise blood samples were corrected for plasma volume shifts. Understanding the adipokine responses and/or adaptations due to exercise is an important step to investigate potential mechanisms by which exercise improves cardiovascular and metabolic health – particularly in those exhibiting characteristics of MetS. Therefore, the purpose of the study was to characterize the adipokine responses to a single dose and to repeated exercise doses in physically inactive and unfit obese males with MetS. A second purpose was to evaluate the accumulated effect of multiple exercise sessions performed on successive days on adipokine responses and markers of insulin sensitivity. An overarching objective was to account for the potentially-confounding influences of plasma volume fluctuations, sporadically controlled throughout the existing literature, so as to provide a clearer characterization of the adipokine response to exercise in men with MetS.

### **Hypotheses and Rationale**

#### *Question 1.*

1a. Will a single session of moderate-intensity aerobic exercise – resulting in 350 kcals of energy expenditure – be sufficient to improve clinical markers of insulin resistance, and increase plasma volume-adjusted adiponectin concentrations (total and HMW) and decrease the leptin concentration in sedentary middle-aged men with MetS?

1b. Will the increase in plasma volume-adjusted adiponectin concentrations and decrease in leptin concentration occur with the improvement in clinical markers of insulin resistance?

#### *Hypotheses*

1a. An increase in plasma volume-adjusted adiponectin concentrations (total and HMW) and a decrease in leptin concentration will not occur after one session of moderate-intensity aerobic exercise in sedentary middle-aged men with metabolic syndrome. An energy expenditure

of 350 kcals – even in sedentary individuals – will not be enough to induce an adipokine response.

1b. Reduced clinical markers of insulin resistance (reduced fasting insulin concentrations and HOMA score) after a single session of moderate-intensity aerobic exercise will occur without corresponding changes in plasma volume-adjusted adipokine concentrations in sedentary middle-aged men with MetS.

#### *Rationale*

Adiponectin does not change with a single exercise session in healthy individuals (26, 72, 98) or in overweight subjects (59). Jamurtas et al. (59) reported that 45 minutes of moderate-intensity exercise did not change adiponectin concentrations in overweight individuals monitored up to 48 hours post-exercise. Similarly, leptin concentrations do not typically change with a single exercise session in healthy males (26, 134). Adiponectin concentrations may increase after a single exercise session when exercise is at high-intensity or high-volume indicating that a substantial caloric expenditure might be necessary to induce changes in this adipokine (11, 121). Likewise, reductions in leptin are reported more frequently when exercise is of high-intensity or results in significant caloric expenditure (800 kcals or more) (11, 23, 79, 81, 129).

Insulin sensitivity increases and insulin resistance decreases transiently after a single exercise session of moderate-intensity without changes in adiponectin concentrations in healthy lean individuals (10) or in overweight males (59). In addition, insulin concentrations decrease and TNF- $\alpha$ , NEFAs, and catecholamine concentrations increase after a single session of moderate- or high-intensity exercise in healthy individuals (26, 69, 98). TNF- $\alpha$  may down-regulate the expression of adiponectin (25) and growth hormone and glucocorticoids may promote leptin production during and in the hours after exercise (7, 73). Therefore, these

adipokines may not be related to the heightened insulin sensitivity or reduced insulin resistance in overweight males after a single exercise session.

*Question 2.*

2. Will multiple sessions of moderate-intensity aerobic exercise, similar in intensity and duration and repeated on four successive days, reduce insulin resistance, increase plasma volume-adjusted adiponectin concentrations (total and HMW); and decrease leptin in sedentary middle-aged men with MetS?

*Hypotheses*

2. Insulin resistance will decrease, plasma volume-adjusted adiponectin concentrations will increase and leptin concentrations decrease, with additional caloric expenditure resulting from repeated exercise sessions on successive days in sedentary obese males with MetS.

*Rationale*

Short-term and long-term exercise training conflicts in relation to changes on adiponectin and leptin (73, 121). However, Kriketos et al. (74) reported a 260% increased in adiponectin after two to three bouts of exercise. Essig et al. (23) reported 22 and 23% decreases in leptin after expending 800 and 1500 kcals running on a treadmill. Although our participants would likely not be able to complete this amount of exercise in one session, they would be able to do this with several successive exercise sessions. Thus, it may be possible that the accumulated energy expenditure from these consecutive exercise sessions will cause changes in these adipokines that facilitates an improvement in insulin sensitivity.

Exercise enhances adipocyte lipolysis and glucose and lipid oxidation in skeletal muscle through several mechanisms that activate calcium calmodulin kinases and AMPK (113, 115). Adiponectin may contribute to the improved insulin sensitivity observed after exercise by facilitating AMPK activity (140). The accumulated energy expenditure of repeated bouts of



moderate-intensity exercise on successive days may induce even more lipolysis, glucose and lipid oxidation by augmenting adiponectin concentrations.

*Question 3.*

3. Will the reduction in insulin resistance and altered adipokine concentrations last several days after exercising in sedentary obese men with MetS?

*Hypotheses*

3. The attenuated insulin resistance and the increase in plasma volume-adjusted adiponectin and the reduction in leptin concentrations are expected to last at least 72 hrs after the last exercise session.

*Rationale*

The attenuated insulin resistance following a moderate-intensity exercise is only a transient response lasting up to 48-hours in those with and without pre-existing insulin resistance (47). Likewise, when adiponectin and leptin concentrations change with exercise, these responses are also transient. Kriketos et al. (74) reported that the increased in adiponectin after exercise was measured at 24 and 36 hours after the last exercise session. Elias et al. (22) reported a decrease in leptin between 30 and 120 minutes after maximal exercise. In addition, Essig et al. (23) reported that reduced leptin concentrations persist for up to 48 hours after exercise. If adiponectin and leptin begin to return to pre-exercise concentrations after a couple of days, these adipokines responses may be related to the return in insulin sensitivity to pre-exercise status. It may also be possible that the stimulus of the accumulated energy expenditure due to repeated bouts of exercise on successive days will alter these adipokines more so than a single session if the transient response to one exercise session does not subside prior to undergoing subsequent exercise 72 hours after the last bout of exercise.

## **Assumptions**

1. We assume that participants were apparently healthy individuals with no underlying cardiovascular or metabolic disease.
2. We assume that participants are not meeting the U.S. surgeon general recommendations for physical activity prior to engaging in this study.
3. We assumed that dietary and nutrition intake just prior and during the exercise intervention has no systematic influence on our variables of interest.

## **Delimitations**

1. Male participants were recruited from the Auburn-Opelika, Alabama area.
2. Only obese males with dyslipidemia and characteristics of metabolic syndrome were recruited for the study.
3. Repeated bouts of exercise on successive days at an intensity of 60-70% of  $\dot{V}O_{2\text{ max}}$  were used in order to expend 350 kcals each session and a total of 1400 kcals in four sessions.
4. Participants were not taking any medications that are known to alter lipid, glucose metabolism or blood pressure

## **Limitations**

1. A non-exercise control group matched for age, physical status and physical activity was not included.
2. A control group completing an equal volume of exercise over the same week but not on successive days was not included.
3. Age-matched men of normal weight were not included as a control group.

## **Significance of the Study**

New updated physical activity recommendations for achieving and maintaining health suggest that every adult should engaged in moderate-or high-intensity physical activity on most days of the week. Thirty-minutes of physical activity should be accumulated each day to achieve a weekly caloric expenditure of 1200 to 2000 kcals in order to obtain the health benefits and reduce the risk of chronic diseases (46, 56). The well-documented improvements in cardiovascular and metabolic health that occur with regular physical activity for previously sedentary individuals may be partly attributed to adipokine-mediated mechanisms (46, 132).

Many adipokines and cytokines are known as acute-phase reactants. They are released into tissues and the circulation in rapid response to metabolic changes (115). Thus, it stands to reason that single episodes of exercise, of sufficient intensity and energy expenditure, may induce an adipokine response that may previously have been attributed to exercise training. However, the limited and equivocal evidence to support this position may be because of tremendous variation in experimental design and methodology employed to explore this line of inquiry. For example, the exercise stimuli varies with respect to the participants' health and fitness status, the timing of blood samples – relative to the last bout of exercise – and whether or not adipokine concentrations in post-exercise blood samples were corrected for plasma volume shifts were seldom reported or controlled. This study will help us understand the adipokine responses and/or adaptations to exercise as and maybe an important step in investigating potential mechanisms by which exercise improves cardiovascular and metabolic health – particularly in those who are physically inactive with MetS.

## CHAPTER II

### REVIEW OF LITERATURE

#### **Metabolic Syndrome, Insulin Resistance and Metabolic Health**

##### *Diagnostic Criteria*

In the last decade several clinical criteria have been used to classify people with MetS (3, 38, 40). The first proposed diagnostic criteria for MetS was published in 1998 by the World Health Organization (WHO) (3). The WHO criteria emphasized insulin resistance as the most important characteristic of MetS (40). Several indirect clinical measures of insulin resistance such as impaired fasting glucose (IFG), impaired glucose tolerance (IGT), or a diagnosis of type 2 diabetes mellitus were suggested as clinical features of insulin resistance (3). In addition to insulin resistance, two or more of the following risk factors should be present: body mass index  $> 30 \text{ kg/m}^2$  and/or waist-to-hip ratio  $> 0.90$  in men or  $> 0.85$  in women; triglyceride concentration (TG)  $> 150 \text{ mg}\cdot\text{dL}^{-1}$ ; high density lipoprotein cholesterol (HDL-C) concentration  $< 35 \text{ mg}\cdot\text{dL}^{-1}$  in men and  $< 39 \text{ mg}\cdot\text{dL}^{-1}$  in women; and systolic blood pressure  $\geq 140$  or diastolic blood pressure  $\geq 90 \text{ mmHg}$  (40).

The National Cholesterol Education Program Adult Treatment Panel III (NCEP-ATPIII) published a slightly different set of diagnostic criteria for MetS in 2001(96). The ATP recommended three or more of the following criteria to characterize MetS: abdominal obesity (waist circumference  $>102$  and  $88$  centimeters in men and women, respectively); TG  $> 150 \text{ mg}\cdot\text{dL}^{-1}$ ; HDL-C  $< 40 \text{ mg}\cdot\text{dL}^{-1}$  in men and  $< 50 \text{ mg}\cdot\text{dL}^{-1}$  in women; systolic blood pressure  $\geq 130$

or  $\geq$  diastolic blood pressure 85 mmHg, and; fasting glucose  $\geq 110 \text{ mg}\cdot\text{dL}^{-1}$  (40, 96). In contrast to the WHO criteria, NCEP identifies abdominal obesity as the primary clinical feature for MetS diagnosis (38).

The International Diabetes Federation (IDF) currently characterizes MetS when central obesity is present, plus two or more of the following risk factors: TG  $\geq 150 \text{ mg}\cdot\text{dL}^{-1}$ ; HDL-C  $< 40 \text{ mg}\cdot\text{dL}^{-1}$  in men and  $< 50 \text{ mg}\cdot\text{dL}^{-1}$  in women; high systolic blood pressure  $\geq 130$  or diastolic blood pressure  $\geq 85 \text{ mm Hg}$ , and; fasting blood glucose  $\geq 100 \text{ mg}/\text{dL}$  (2). Distinguishing features of the WHO, NCEP-ATPIII, and IDF are presented in table 1.

**Table 1. Clinical Criteria for the Diagnosis of Metabolic Syndrome**

<i>Clinical Measure</i>	<i>WHO (1998) (3)</i>	<i>NCEP-ATPIII (2001) (96)</i>	<i>IDF (2005) (2)</i>
Insulin Resistance	IGT, IFG, T2D	none	none
or			
Fasting Glucose		$\geq 110 \text{ mg}\cdot\text{dL}^{-1}$	$\geq 100 \text{ mg}\cdot\text{dL}^{-1}$
Abdominal obesity	WHR 0.90 (men)	102 cm (men)	94 cm (men)
or	WHR 0.85 (women)	88 cm (women)	80 cm (women)
Body weight	BMI $> 30 \text{ kg}\cdot\text{m}^2$		
Triglycerides	$\geq 150 \text{ mg}\cdot\text{dL}^{-1}$	$\geq 150 \text{ mg}\cdot\text{dL}^{-1}$	$\geq 150 \text{ mg}\cdot\text{dL}^{-1}$
HDL-C	$< 35 \text{ mg}\cdot\text{dL}^{-1}$ (men)	$< 40 \text{ mg}\cdot\text{dL}^{-1}$ (men)	$< 40 \text{ mg}\cdot\text{dL}^{-1}$ (men)
	$< 39 \text{ mg}\cdot\text{dL}^{-1}$ (women)	$< 50 \text{ mg}\cdot\text{dL}^{-1}$ (women)	$< 50 \text{ mg}\cdot\text{dL}^{-1}$ (women)
Blood Pressure	SBP $\geq 140 \text{ mm Hg}$	SBP $\geq 130 \text{ mm Hg}$	SBP $\geq 130 \text{ mm Hg}$
	DBP $\geq 90 \text{ mm Hg}$	DBP $\geq 85 \text{ mm Hg}$	DBP $\geq 85 \text{ mm Hg}$

WHO = World Health Organization; NCEP-ATPIII = National Cholesterol Education Program Adult Panel III; IDF = International Diabetes Federation; HDL-C = high density lipoprotein cholesterol; IGT = impaired glucose tolerance as defined as glucose  $\geq 140 \text{ mg}\cdot\text{dL}^{-1}$  and  $\leq 200 \text{ mg}\cdot\text{dL}^{-1}$  from a 2-hour glucose tolerance test; IFG = impaired fasting glucose as defined as glucose concentrations of  $\geq 100 \text{ mg}\cdot\text{dL}^{-1}$  or  $\geq 110 \text{ mg}\cdot\text{dL}^{-1}$  and  $\leq 125 \text{ mg}\cdot\text{dL}^{-1}$ ; T2D = Type 2 Diabetes; WHR = Waist-to-hip ratio; BMI = body mass index; SBP = systolic blood pressure; DBP = diastolic blood pressure.

### *Prevalence of MetS*

The metabolic syndrome has been described as a worldwide pandemic (38). Most countries in the world using WHO, NCEP, and/or IDF clinical criteria have a prevalence of MetS between 20 to 30% (38). A 2002 survey indicated that approximately 24% of US adults have MetS (29). Excess body weight appears to have a tremendous impact on prevalence, as MetS was present in 22.4% of overweight and 59.6% in obese men compared to only 4.6% in normal weight males (105).

Approximately 25% of the population in Europe have MetS, a prevalence that is similar to that of US adults (4, 15, 38). In India, the prevalence of MetS is about 18.3% using the ATP III diagnostic criteria; however when IDF criteria was used, the prevalence of MetS increased to 25.8% (16). In Latin American countries the prevalence of MetS is higher than in the US or Europe (38, 87). For instance, the prevalence of MetS in Mexico City in 1999 was 39.9% in men and 59.9% in women (87) .

### *Cardiovascular Fitness and Physical Inactivity*

Park and Colleagues (105) reported a significantly greater odds ratio for MetS in physically inactive versus active men. In this study physical inactivity was defined by the amount of participation in activities such as walking, running, bicycling, and aerobic dancing during the previous month. A similar relationship between self-reported physical activity and metabolic risk factors for MetS was observed in 1,420 young adults from the Bogalusa Heart Study. Physical activity was assessed using a questionnaire that measures the time and level of exertion in work, leisure, television watching, and video gaming. Moderate and very active individuals had significantly less metabolic risk factors, such as larger waist girth, elevated blood pressure, total cholesterol/HDL-C ratio, and insulin resistance index, than inactive individuals (42). Lakka et al. (77) reported that individuals who performed exercise at moderate intensity for

less than 1 hour per week were 60% more likely to have MetS than those who performed exercise for 3 or more hours per week.

Cardiorespiratory fitness has also been linked to the prevalence of MetS. LaMonte et al. (78) studied the relationship between cardiorespiratory fitness and MetS in 10,498 middle-aged men and women. Cardiorespiratory fitness was estimated at baseline from the time completed during a maximal treadmill test. MetS prevalence was determined at 5.7 years of follow-up. Those people with higher cardiorespiratory fitness had lower rates of MetS at follow-up than those with less cardiorespiratory fitness suggesting that individuals with poor cardiorespiratory fitness are at higher risk for developing MetS (78).

#### *Recommendations for Managing MetS*

In 2005, the American Heart Association (AHA) and the National Heart, Lung and Blood Institute (NHLBI) issued a Scientific Statement presenting several recommendations for managing MetS. A primary recommendation was to promote regular moderate-intensity physical activity (40) because regular continuous or intermittent bouts of moderate-intensity aerobic exercise can favorably alter the cardio-metabolic risks factors of MetS (40). The health benefits of aerobic exercise training include weight loss (12), reductions in body fat (110) and waist circumference (12), improved lipid profile (20, 124), increased insulin sensitivity (12, 147), and improved clinical markers of insulin resistance such as HOMA score (59).

#### **Exercise, Glucose Uptake and Insulin Sensitivity**

A single exercise session and regularly-practiced exercise consistently improves cellular glucose uptake by means that are independent of insulin as well as insulin-dependent processes (52, 111, 113, 137, 147). Exercise transiently increases glucose transport capacity in skeletal muscle by enhancing GLUT-4 expression and translocation to the cell membrane (113, 137).

### *Insulin-Independent Glucose Uptake*

Muscle contractile activity enhances glucose uptake by stimulating AMPK and by transiently increasing intracellular calcium (111, 113). AMPK works when intracellular energy stores are being depleted at a faster rate than they are being restored. For example, signals of change in cellular energy status such as an increase in the AMP/ATP ratio stimulate AMP-activated protein kinase activity (113). During exercise ATP is hydrolyzed forming ADP. ADP helps to replenish ATP by donating phosphate to another ADP. The result of this transfer is ATP and AMP. When more AMP is produced during exercise there is a conformational change in AMPK that predisposes the molecule to phosphorylation and activation (60, 61). AMPK activity inhibits acetyl-CoA carboxylase (ACC) which reduces cytosolic malonyl-CoA and its inhibition of carnitine palmitoyltransferase 1 (CPT-1). CPT-1 facilitates the transport of fatty acids into the mitochondria for oxidation. The greater fatty transport and oxidation diminishes cytosolic fatty acid content – including diacylglycerol (DAG) and ceramides known to inhibit GLUT-4 translocation to the cell surface. Therefore, a lower cytosolic DAG and ceramide is thought to improve GLUT-4 translocation and glucose uptake (21).

Intercellular calcium is important for muscle contraction and may partially regulate glucose uptake by the activation of calcium calmodulin signaling and calmodulin-dependent protein kinases such as protein kinase II and protein kinase C (111, 113). These calmodulin protein kinases may directly increase GLUT-4 translocation. The calmodulin kinases can indirectly increase GLUT-4 translocation and may occur through activation of AMPK and Akt substrate protein 160 (AS160) (113, 136).

### *Insulin-Mediated Glucose Uptake*

Exercise training enhances the activity of the insulin signaling through insulin receptor substrates 1 (IRS-1) and IRS-2 and phosphatidylinositol 3-kinase (PI3-kinase) in skeletal muscle.



The IRS, in turn, enhances protein kinase B (Akt) and Akt substrate protein 160 (AS160). Akt and atypical protein kinase C (aPKC) stimulate insulin dependent GLUT-4 translocation to the cell membrane (113, 147). The enhance activity of the IRS-1 and PI3-kinase and the increase expression of GLUT-4 transporters in the skeletal muscle are some of the mechanisms by which exercise may improve insulin sensitivity (147). See figure 1.

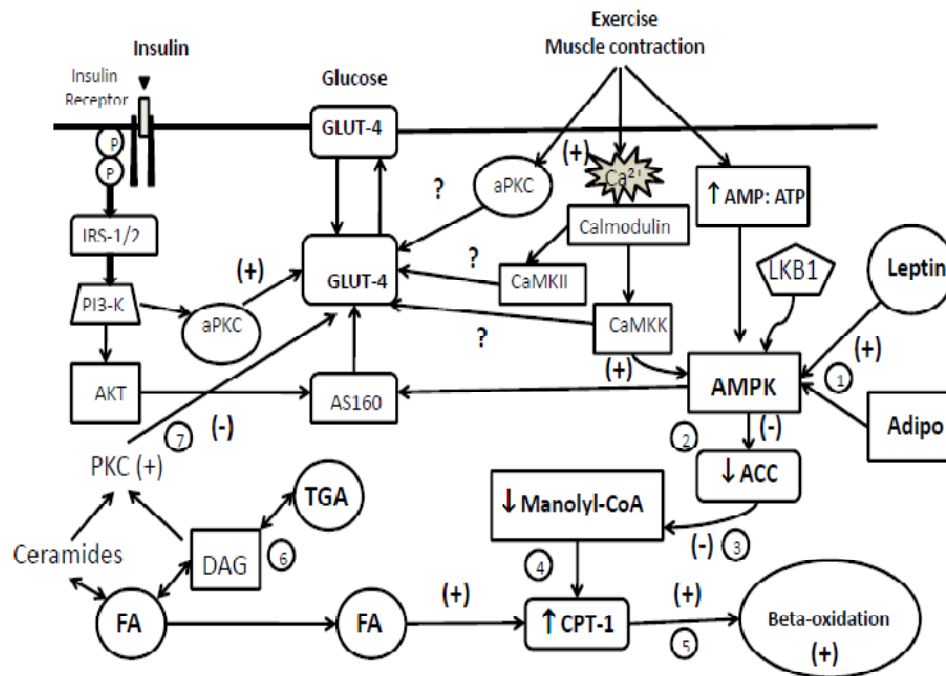

**Fig. 1. Proposed Model for Exercise and Insulin Sensitivity.** Adapted from Rockl et al. (113). Proposed model for the signaling pathways mediating insulin-dependent and insulin-independent processes and how leptin and adiponectin stimulate fatty acid oxidation reduced lipid accumulation and improve insulin sensitivity. **1.** = leptin and adiponectin activates AMPK. **2.** = AMPK inhibits ACC. **3.** = ACC reduces Malonyl-CoA. **4.** = Malonyl-CoA releases its inhibition in CPT-1. **5.** = CPT-1 increases the transport of FA into the mitochondria for oxidation. **6.** = The enhanced oxidation of FA reduces DAG and Ceramides. **7.** = The reduction in lipid content increases the activity of PKC and improves GLUT-4 translocation. IRS-1/2 = insulin receptor substrate 1/2; PI3-K = phosphatidylinositol 3-kinase; AKT = protein kinase B; AS160 = Akt substrate protein 160; aPKC = atypical protein kinase C; CaMKII = calcium calmodulin-dependent protein kinase II; CaMKK = calcium calmodulin-dependent protein kinase kinase; AMPK = adenosine monophosphate protein kinase; GLUT-4 = glucose transporter 4; ACC = acetyl-CoA carboxylase; FA = fatty acid; TAG = triglyceride; DAG = diacylglycerol; CPT-1= carnitine palmitoyltransferase 1; PKC = protein kinase C; (+) = activation; (-) inhibition.

### *Hormonal Influences on Adipokines and Insulin Sensitivity*

During exercise, the increased sympathetic nervous activity and release of catecholamines from the adrenal gland facilitates the mobilization of fatty acids from adipose tissue and from intramyocellular fat for lipid oxidation in skeletal muscle (36). The heightened sympathetic nervous activity and humoral catecholamines inhibit insulin release and increase glucagon during exercise. Catecholamines also stimulate gluconeogenesis and glucose release from the liver (92). Catecholamines and the sympathetic nervous system stimulate the hypothalamus to release corticotrophin releasing hormone (CRH) resulting in the release of adrenocorticotrophic hormone (ACTH) and cortisol. The cortisol response to stress, such as physical exertion, helps to maintain glucose concentrations and promotes lipid utilization for energy (92). Other counter-regulatory hormones such as growth hormone, and thyroid hormone triiodothyronine (T3) are elevated as a consequence of exercise (92). Growth hormone promotes adipose tissue lipolysis during exercise and T3 accelerates metabolic rate and increases adipose tissue lipolysis.

Exercise-induced changes in adiponectin and leptin may contribute to the improved insulin sensitivity after exercise (21, 94, 115, 140). Adiponectin increases glucose uptake by improving GLUT-4 translocation to the cell membrane through the activity of AMPK (21). Similarly, leptin improves insulin sensitivity in the skeletal muscle via AMPK activation and by increasing GLUT-4 number in the cell membrane (21). Several hormones may have an influence on adiponectin or leptin secretion during exercise. Insulin, catecholamines, and cortisol may suppress adiponectin gene expression (24, 25); whereas, growth hormone may increased the gene expression of adiponectin (138). Growth hormone and cortisol has been shown to enhanced leptin production (7). These exercise-induced changes are transient and the hormone concentrations return to their baseline values several hours after exercise (34).

Exercise improves the action and sensitivity of leptin in the hypothalamus (28). Leptin injections in the hypothalamus of exercising rats increased the hypothalamic phosphorylation of leptin receptor (OB-Rb) and increased the activity of intracellular signaling proteins janus kinase (JAK) to a greater extent than that observed in sedentary animals (28). JAK binds to the leptin receptor via tyrosine phosphorylation which then activates the signal transducer and activators of transcription-3 (STAT3) and initiates a downstream protein kinase signaling transduction to the cell nucleus where it regulates the transcription of genes involved in cellular growth regulation (1). An increase in leptin sensitivity in the hypothalamus would reduce appetite and eating behaviors (115).

In summary, exercise can increase glucose uptake via insulin-independent and insulin-dependent mechanisms. Insulin-independent mechanisms included muscle contractile activity that enhanced glucose uptake via activation of AMPK and through the release of intercellular calcium (113, 137, 147). AMPK and other calcium protein kinases eventually promote GLUT-4 translocation to the cell surface and improve skeletal muscle glucose uptake. Insulin-dependent glucose uptake is improved through IRS-1 and IRS-2. Several hormones such as insulin, catecholamines, cortisol, and growth hormone influence adipokines and insulin sensitivity during exercise (24, 25, 92, 138). Insulin, catecholamines, and cortisol may inhibit adiponectin gene expression (24, 25) and growth hormone may increase it (138). Growth hormone release is greater with lower leptin concentrations and insulin stimulates leptin secretion (92). Adiponectin and leptin may improve insulin sensitivity by activating AMPK and by stimulating lipid and glucose metabolism.

## **Role of the Adipose Tissue on Metabolic Health**

### *Functions of the Adipose Tissue*

Brown adipose tissue and white adipose tissue (WAT) are the two primary types of adipose tissue found in mammals (35). The main function of brown adipose tissue is to generate body heat in animals and newborns. WAT functions as a lipid storage site and as an endocrine organ that secretes a host of polypeptide molecules called adipokines (13, 35, 57, 67, 115). Adipokines are signaling molecules that modulate glucose and lipid metabolism, inflammation, immune responses and vascular health within adipose and other tissues (67, 82, 140). In particular, adiponectin and leptin are of primary importance with respect to MetS because these adipokines function as insulin-sensitizing agents in WAT, skeletal muscle, heart, pancreas, and the liver (21, 118, 140).

### *Adiponectin Concentrations*

Adiponectin is the most abundant plasma protein found in the circulation (13, 118). In humans, adiponectin concentrations range from 3 to 25  $\mu\text{g/ml}$  (50, 54, 63, 102, 112, 119, 135). Elite rowers have adiponectin concentrations at the upper end of this range (63). The average adiponectin concentrations in healthy men and women are 7 to 9  $\mu\text{g/ml}$  (102). Lower adiponectin concentrations have been reported in people with obesity (135), patients with type 2 diabetes mellitus (50), cardiac patients (102) and individuals with MetS (54, 112). Based on observations reported by Ouchi et al. (102) Hotta et al. (50) and Ring-Dimitrio et al. (112), it appears that women generally tend to have higher adiponectin concentrations compared with men. In addition, athletes and healthy individuals have higher adiponectin concentrations than obese, diabetic, and cardiac patients (50, 102, 112). Please see table 2.

**Table 2. Concentrations of Adiponectin on Different Populations**

<i>Study</i>	<i>Participants</i>	<i>N</i>	<i>Adiponectin (ug/mL)</i>
Ouchi et al. 1999 (102)	Healthy male	58	7.4 ± 3.5
	Healthy female	20	9.3 ± 6.8
Hotta et al. 2000 (50)	Cardiac male	30	3.4 ± 1.8
	Cardiac female	12	4.3 ± 1.5
	Diabetic male patients without CAD	82	6.6 ± 0.4
	Diabetic female patients without CAD	37	7.6 ± 0.7
Ring-Dimitrio et al. 2006 (112)	Diabetic male patients with CAD	45	4.0 ± 0.4
	Diabetic female patients with CAD	19	6.3 ± 0.8
Ring-Dimitrio et al. 2006 (112)	Obese male	22	5.7 ± 2.4
	Obese females	14	9.3 ± 4.5
Jürimäe et al. 2006 (63)	Elite male rowers	11	25.4 ± 9.9

**CAD** = cardiovascular disease; **N** = number of participants. Data was obtained from references (50, 63, 102, 112)

### *Forms of Adiponectin*

Adiponectin is made up of 247 amino acids and contains four-domains: a collagen domain; a globular domain; a variable region, and; an amino terminal sequence (103, 118). Adiponectin is released from the adipocyte in full-length and globular forms (21). The full-length form can vary in structure and molecular weight from low molecular weight (LMW), medium molecular weight (MMW) and high molecular weight (HMW) (21, 133). Pajvani et al. (104) suggested that HMW adiponectin is a better indicator of insulin sensitivity in humans than total adiponectin concentrations because HMW is the only oligomer that promotes the insulin sensitizing effect in the skeletal muscle and in the liver (70, 80, 104, 146). Lara-Castro et al. (80) investigated the relationship between total plasma concentrations of adiponectin, HMW, LMW, and the HMW-to-total-adiponectin ratio with insulin sensitivity, abdominal fat distribution, LDL-C, and HDL-C on 25 normoglycemic individuals, 22 insulin-resistant normoglycemic, and 21 patients with type 2 diabetes mellitus. Normoglycemic individuals exhibit higher total and HMW adiponectin concentrations than insulin resistant patients. Total and HMW adiponectin

were correlated with insulin sensitivity ( $r = 0.45$  for total adiponectin,  $r = 0.47$  for HMW). The LMW ( $r = 0.31$ ) and the HMW-to-total-adiponectin ratio ( $r = 0.29$ ) accounted for less variation in insulin sensitivity. Inverse correlations with abdominal fat were reported for total adiponectin ( $r = -0.30$ ) for HMW, ( $r = -0.38$ ) and for the HMW-to-total-adiponectin ratio ( $r = -0.34$ ).

Conclusions from this study were that higher concentrations of adiponectin – especially HMW adiponectin – are associated with a greater insulin sensitivity and that HMW adiponectin exhibits stronger correlations with the risks factors of MetS than total or LMW adiponectin concentrations.

### *Adiponectin Functions*

Adiponectin promotes glucose utilization and lipid oxidation in skeletal muscle and in the liver primarily by activating AMPK (13, 140). An increase in AMPK activity is known to stimulate fatty acid oxidation and glucose uptake and result in accelerated metabolism (21).

Adiponectin activates the proliferator-activating receptor alpha (PPAR $\alpha$ ). PPAR $\alpha$  is a nuclear receptor that is found in the liver, heart, skeletal muscle and adipose tissue (65). Adiponectin increases fatty acid oxidation and lowers triglyceride content in skeletal muscle by increasing AMPK and PPAR $\alpha$  activity (65). PPAR $\alpha$  may increase the expression of fatty acid transporters in the liver and improve lipid metabolism. PPAR $\alpha$  also stimulate the muscle expression of ACC and CPT-1, two key enzymes involved in fatty acid oxidation (44). The improvement in lipid metabolism and reduction of ectopic lipid storage in skeletal muscle and in the liver may improve insulin sensitivity (41, 44).

In addition to stimulating metabolism, adiponectin has demonstrated anti-atherogenic and anti-inflammatory functions (13, 82, 102). Adiponectin prevents monocyte adherence and migration across the endothelium by inhibiting the expression of VCAM-1 and ICAM-1(89). Adiponectin also inhibits the expression of macrophage scavenger receptors; thereby, decreasing

the uptake of low-density lipoprotein cholesterol (LDL-C) and attenuating the conversion of monocytes to macrophages to foam cells. Smooth muscle cell proliferation and migration may also be reduced from adiponectin's influence on the vasculature (89, 102).

### *Adiponectin Receptors*

Two adiponectin receptors, Adipo R1 and Adipo R2, have been identified in the skeletal muscle, adipose tissue, the pancreas, and liver (65, 68, 139, 146). These receptors enhance fatty acid oxidation and glucose uptake through AMPK and PPAR $\alpha$  activation (65). Both Adipo R1 and R2 receptors have been found in skeletal muscle while Adipo R2 is currently thought to be the only adiponectin receptor found in the liver (21). The globular domain found in LMW, MMW, and HMW adiponectin stimulates Adipo R1 receptors while the full-length domain, found only in HMW, stimulates Adipo R2 receptors (21, 65, 139). The strong association between HMW adiponectin and insulin sensitivity is thought to be due to the fact that it can stimulate both Adipo 1 and 2 receptors (65, 80).

The expression of adiponectin receptors in skeletal and adipose tissues is decreased in obesity (127); thereby, reducing the sensitivity of these tissues to adiponectin and contributing to insulin resistance (65). Exercise has been shown to increase the expression of Adipo R1 and Adipo R2 in skeletal muscle and adipose tissue (9, 14, 100). Recently, Christiansen et al. (14) reported that exercise training, diet-induced weight loss, and the combination of both interventions increased the expression of skeletal muscle and adipose tissue Adipo R1 and Adipo R2 in obese men and women. Insulin can also reduce the number of Adipo R1 and Adipo R2 by several insulin signaling pathways (127). Fasting for 48 hours increases Adipo R1 and R2 receptors in the skeletal muscle and liver, while eating reduces adiponectin receptors within 6 hours of the meal (127). In summary, exercise may contribute to attenuating insulin resistance by increasing the expression of adiponectin receptors in skeletal muscle and adipose tissue.

### *Leptin Concentrations*

Circulating concentrations of leptin in humans range from 2 to 14 ng/mL (23, 31, 62, 106, 107, 110, 144). Males tend to have lower leptin concentrations compared with women (73, 107). Lower concentrations of leptin, ranging from 2 to 3 ng/mL, versus age and gender matched controls have been reported in athletes (62, 79). Greater leptin concentrations have been reported in sedentary and obese individuals (31, 51, 107) and those with MetS (144) as compared to trained, normal weight and healthy.

### *Regulation and Functions of Leptin*

Leptin, one of the first adipokines to be identified, is primarily secreted from white adipose tissue (33). However, the gastric epithelium and skeletal muscle also produce small quantities of leptin (33, 48). Leptin is influenced by fluctuations in energy intake and is thought to be a “starvation signal”. Leptin decreases rapidly during fasting leading to a slowed metabolic rate. Lower leptin concentrations will also stimulate appetite and eating (32).

Leptin regulates satiety and appetite by stimulating specific receptors in the hypothalamus (32, 33). In the brain, leptin activates anorexigenic peptides such as proopiomelanocortin and cocaine- and amphetamine-regulated transcripts that dampen eating behavior and feeding (83). Leptin also inhibits orexigenic peptides, such as neuropeptide Y and the agouti gene-related protein, that enhance appetite and eating (115, 120). Thus, an increase in leptin concentration would reduce appetite and eating behavior and decreases in leptin concentration would enhance appetite and eating behavior in normal leptin regulation.

As with adiponectin, leptin promotes lipid oxidation in skeletal muscle by activating AMPK (21, 123). Two-weeks of leptin administration in mice increased the expression and activity of AMPK by 2-to-3 fold, increased phosphorylation of ACC by 1.5-to-2 fold, and improved the rate of fatty acid oxidation in the mitochondria (123). Insulin resistance was



partially ameliorated and glucose metabolism was improved in mice treated with injections of leptin. Thus, leptin also increases insulin sensitivity and prevents lipid accumulation by reducing the intracellular lipids in skeletal muscle and in the liver (123, 141).

Over time, leptin concentrations adapt to changes in fat mass. An increase in fat mass elevates leptin while lower leptin results when fat mass is reduced in a normal functional of leptin (83). “Leptin resistance” may develop with excess fat accumulation and dysfunctional adipose tissue metabolism due to ischemia, inflammation, and oxidation (6). Leptin resistance, is a condition characterized by an increase in leptin production from the adipose tissue, attenuated leptin receptor sensitivity, and impaired peripheral sensitivity and transport of leptin across the blood-brain barrier (5, 21, 33, 117). In contrast to the findings of Steinberg et al. (123), Scarpace and colleagues (117) observed that administration of leptin injections in mildly obese Brown Norway rats enhanced leptin resistance and the authors suggested that may be secondary to obesity.

### *Leptin Receptors*

Two major leptin receptor isoforms have been found in the hypothalamus, skeletal muscle and in the liver (21, 115). The long receptor isoform (OB-Rb) is expressed in the hypothalamus and stimulates JAK and STAT3 (21, 33). The short receptor isoform (OB-Ra) is expressed in peripheral tissues and in the choroid plexus of the brain and stimulates only the JAK pathway. The OB-Ra short isoform may serve to transport leptin across the blood brain barrier (11). Both, the OB-Rb and OB-Ra isoforms are expressed in skeletal muscle; however, the majority of leptin receptors found in skeletal muscle are the short isoform OB-Ra (21). Leptin signaling in skeletal muscle activates OB-Ra receptors which trigger AMPK and STAT-3 via tyrosine phosphorylation (21). As mentioned previously, AMPK inhibits ACC and improves the rate of fatty acid oxidation in the mitochondria and STAT-3 facilitates downstream protein

kinase signaling to the cell nucleus where it regulates the transcription of genes related to cellular growth regulation (1).

### **Physical Activity, Aerobic Exercise and Adipokines**

There are several experimental design features and protocol characteristics that may influence our interpretation of adiponectin and leptin responses to exercise. These factors included: participant characteristics, the amount and intensity of exercise, the timing of the blood samples after exercise and whether or not samples were corrected for plasma volume changes. In addition, changes in body weight or body fat, diet, the amount of physical activity participation outside of the study requirements and cardiorespiratory fitness are other characteristics that should be taken into consideration. These study characteristics are varied and inconsistent and make interpretation of the exercise literature somewhat difficult (22, 23, 26, 59, 62-64, 72, 98, 109).

#### *Evidence from Cross-sectional Studies: Exercise and Adipokines*

Physical activity and cardiorespiratory fitness appear to be related to adiponectin concentrations in the cross-sectional literature (9, 128, 143). Individuals self-reporting higher physical activity or fitness have higher adiponectin concentrations when compared to those reporting or exhibiting lower amounts of physical activity (9, 122, 128, 143).

Tsukinoki et al. (128) reported that individuals who exercise two or more times per week had higher adiponectin concentrations ( $6.1 \pm 1.9 \mu\text{g/mL}$ ) than those who exercised less than two times per week ( $2.9 \pm 0.8 \mu\text{g/mL}$ ). Blüher and co-workers (9) observed that adiponectin concentrations were lower in individuals with type 2 diabetes ( $3.4 \pm 0.4 \mu\text{g/mL}$ ) and impaired glucose tolerance ( $4.3 \pm 0.3 \mu\text{g/mL}$ ) than in individuals with normal glucose tolerance and higher physical activity concentrations ( $8.9 \pm 0.4 \mu\text{g/mL}$ ).

Yokoyama and colleagues (143) investigated whether a number of lifestyle behaviors, including physical activity, influences insulin resistance and adiponectin concentrations. Plasma adiponectin and insulin concentrations and self-administered physical activity questionnaires were obtained from each participant. Multiple logistic regression analysis was used to determine how unhealthy lifestyle behaviors affect adiponectin concentrations. The researchers observed that lack of physical activity and higher BMI, among other unhealthy lifestyle behaviors, were independently associated with low adiponectin concentration and insulin resistance.

Leal-Cerro and co-workers (81) compared the concentrations of leptin in male marathon runners compared with non-obese sedentary males. The authors reported that marathon runners had lower leptin concentrations ( $2.9 \pm 0.2$  ng/mL) than their sedentary counterparts ( $5.1 \pm 0.6$  ng/mL). However, the ratio of leptin concentrations per kilogram of body fat was not different between groups. Thus, the difference in leptin concentrations between these groups was explained by the differences in body fat observed between marathoners and their sedentary counterparts.

Hickey and colleagues (49) investigated the relationship between leptin concentrations, body fat distribution and cardiorespiratory fitness in 333 males and 63 females. Consistent with the current literature (31, 51, 62, 79, 107, 131), leptin concentrations were higher in women ( $15.2 \pm 1.3$  ng/mL) than in men ( $6.9 \pm 0.3$  ng/mL); however, total body fat (males  $20.5 \pm 0.5$  kg; females  $20.4 \pm 1.5$  kg) was not different between men and women. Leptin was related to total body fat and this relationship remained significant after adjusting for age, maximal treadmill time, waist circumference and fasting insulin concentrations. The authors did not measure body fat distribution and may be the discrepancies in these results are due to differences in regional body fat in men and women. Cardiorespiratory fitness did not contribute independently to the

variation in leptin concentrations suggesting that cardiorespiratory fitness did not have an effect in leptin concentrations in this study.

### *Aerobic Exercise Training on Adiponectin*

Consistent with the cross-sectional literature (9, 128, 143), several investigators have reported that aerobic exercise training increases total adiponectin (9, 53, 74, 101, 112).

Reduction in body weight and/or body fat are observed with exercise training in most (9, 53, 101, 112) but not all of the studies where adiponectin concentrations are significantly increased (74).

Blüher and colleagues (9) studied the effect of 4 weeks of exercise training on adiponectin concentrations and the tissue expression of adiponectin receptors in 20 participants with impaired glucose (IGT), 20 with previously-diagnosed type 2 diabetes mellitus, and 20 with normal fasting glucose. Participants cycled, ran, and swam for 60 minutes on 4 days per week. All three groups significantly increased adiponectin concentrations and insulin sensitivity after training. The skeletal muscle expression of Adipo R1 and Adipo R2 was increased in all groups suggesting a heightened tissue sensitivity to adiponectin in all groups (9). Adiponectin increased 12.6% among those with normal fasting glucose, by 97% in those with IGT and by 87% in those with T2D. Thus, adiponectin increased in all groups, but was greater in individuals with insulin resistance and type 2 diabetes. Body weight significantly decreased in all groups; but, the change in body weight was greater in the IGT group. In a similar study design, Oberback et al. (101) reported that adiponectin increased in IGT and T2D participants, but not in individuals with normal fasting glucose after 4 weeks of regularly practice exercise. Based on these two studies (9, 101) it appears that adiponectin concentrations in IGT and T2D individuals may have responded more so than the participants with normal fasting glucose. However, because the IGT

and T2D participants lost more body weight, it can not be rule out that weight loss had a significant influence on the different adiponectin responses between these groups.

Hsied and Wang (53) observed that adiponectin concentrations in both men and women increased by 34% in the young and by 53% in the older group after 52 weeks of moderate-intensity walking or jogging for 20 minutes per day. Body fat decreased 3% and 8% in the young and older groups, respectively. Likewise, adiponectin concentrations increased by 32% after 52 weeks of moderate-intensity cycle ergometry 3 days per week in men with MetS (112).

Hulver and colleagues (56) investigated the adiponectin and insulin sensitivity responses to exercise training versus weight loss by gastric by-pass surgery in sedentary overweight individuals for 24 weeks. The exercise program consisted of 45 minutes of walking, running, cycling, or climbing at 65% to 80% of  $\dot{V}O_{2max}$ . The researchers reported no change in adiponectin concentrations, body weight or body fat in the exercise group; however, body weight decreased 56.6 kg and adiponectin concentrations increased 281% in the weight loss group. Insulin sensitivity increased in both groups after the intervention. Results from this study may be used to bolster the argument that weight loss is responsible for the improvement in adiponectin concentrations after exercise training. Thus, it appears that adiponectin is unaltered with exercise training when modest reductions in body weight and/or body fat occurred.

O'Leary and colleagues (100) observed that adiponectin was unchanged after 12 weeks of exercise training for 60 minutes at 65% to 85% of  $HR_{max}$  in sedentary obese men and women despite significant reductions in body weight and body fat. Subcutaneous and visceral adipose tissues and insulin resistance were also significantly reduced after training. However, the change in insulin resistance was not correlated with changes in body weight or subcutaneous fat, but it was positively associated with changes in visceral fat.

Adiponectin concentrations can increase after exercise training without changes in body weight (74). For instance, Kriketos and colleagues (74) reported that adiponectin concentrations increase by 134% in 19 overweight and obese males after 10 weeks of walking and jogging at 55 to 70% of  $\dot{V}O_{2\max}$  for 40 minutes 4 to 5 days per week. Insulin sensitivity increased and body weight was unchanged after exercise training.

Several investigators have reported that aerobic exercise training does not change total or HMW adiponectin (100, 142). Yatagai and co-workers (142) investigated adiponectin and insulin sensitivity responses to exercise training in healthy sedentary males. Exercise training consisted of cycle ergometry 5 days per week for 60 minutes per day at lactate threshold. Blood samples were taken before training and again at 16 hours and one week after the last exercise session. BMI and body fat remained unaltered after exercise training and cardiorespiratory fitness increased by 7%. Plasma adiponectin concentrations decreased and insulin sensitivity improved at 16 hours after the last bout of training but both variables remained no different from pre-training concentrations one week after the last bout of exercise training. Thus, the changes observed in adiponectin concentrations and insulin sensitivity after exercise were likely due to an acute response and not an adaptation of long-term exercise training.

In summary, half of the studies demonstrated an increased in adiponectin concentrations after exercise training. If exercise has an effect, it is to increase adiponectin concentrations. This appears to occur with modest exercise in overweight, obese, IGT, and T2D individuals (9, 101, 112), but not always (56, 100) and more often when changes in body weight and/or body fat occurred (9, 53, 101, 112). Most researchers reported that insulin sensitivity improved after training (9, 56, 74, 101, 142). It may be also possible that the sensitivity of the adiponectin was improved with exercise training as reported previously in obese and insulin-resistant individuals (9, 100). In contrast, adiponectin concentrations appear to be resistant to exercise-induced

changes in healthy individuals or trained athletes with normal BMI and/or body fat and who already have high concentrations of adiponectin concentrations before exercise training (63, 142). Cardiorespiratory fitness improvement in these studies ranged from 3% to 14% (63, 100, 101, 112, 142). The improvement of cardiorespiratory fitness was higher in obese sedentary individuals than the improvement observed in athletes. However, cardiorespiratory fitness and the improvements in cardiorespiratory fitness with training do not appear to influence adiponectin concentrations as the improvement in cardiorespiratory fitness was related to the increase in adiponectin in only two studies (101, 112). The timing of the blood samples in these studies is rarely reported, so the discrepancies in these studies could be due to an acute effect and not due to training adaptation (142). Please see table 3.

#### *Aerobic Exercise Training on Leptin*

Exercise training has been shown to decrease leptin concentrations in middle-aged healthy men and women (107), in obese men (106) and in men with metabolic syndrome (110) when weight loss occurred along with exercise training (43, 58, 106, 107, 110). Perusse et al. (107) observed that leptin decreased by 15% in men but not women after 20 weeks of exercise training. Cardiorespiratory fitness increases by 16% in men and by 19% in women but percentage body fat was decreased by 1.3% in men but not in women. Insulin sensitivity was not improved in either men or women.

Halle and colleagues (43) examined the effect of weight loss by exercise and dietary restriction on leptin concentrations in middle-aged obese males with type 2 diabetes mellitus. Participants completed 30 minutes of cycle ergometry at 70% of heart rate max to achieve an exercise energy expenditure of 1100 kcal per week for 4 weeks. An additional 1100 kcal of weekly energy expenditure was achieved by hiking, swimming, and playing water games. During the study, all participants had the same hypo-caloric diet consisting of 1000 kcal/day and

included 50% carbohydrates, 25% fats and 25% proteins. Body weight decreased by an average of 4 kilograms, leptin concentrations decreased 29%, and insulin sensitivity improved. However, the researchers were not able to distinguish which of the factors: the energy expenditure or improvement in cardiorespiratory fitness with exercise, energy restriction through the hypocaloric diet, or weight loss was the stimulus for the observed decreases in leptin and improvements in metabolic health.

Pasman et al. (106) examined the effect of exercise training and weight loss on leptin concentrations in middle-aged obese males. All participants consumed a hypo-caloric diet for 2 months and exercised 3 to 4 times per week for 60 minutes by running, cycling, and swimming at moderate-intensity. One group trained for 16 months and another group served as a control and exercised for 4 months and then stopped. Body weight, body fat and insulin concentrations decreased after 16 months of exercise training. Cardiorespiratory fitness improved by 19% in the exercise group and by 12% in the control group. The researchers observed that leptin concentrations decreased by 23% after 16 months of exercise training versus no change in the control group. The change in leptin was independent of changes in plasma insulin and body fat indicating that leptin concentrations can decrease without changes in insulin or body fat. Similarly, Thong and colleagues (125) investigated the leptin responses to weight loss and exercise in relation to changes in visceral and subcutaneous adipose tissue in middle-aged sedentary obese males. Participants were randomly assigned to diet-induced weight loss, exercise-induced weight loss, and exercise with weight maintenance or a control group for 12 weeks. The exercise training consisted of brisk walking or jogging at 75% of  $\dot{V}O_{2max}$  until each participant expended 700 kcal per session. The authors reported that leptin concentrations decreased in diet-induced weight loss and the exercise induced-weight loss groups, but leptin concentrations did not change when exercise was not accompanied by weight loss.



Cardiorespiratory fitness improved by 20% in exercise with weight maintenance and by 24% in exercise-induced weight loss group and no change was found in the diet-induced weight loss or in the control group.

**Table 3. Effect of Exercise Training on Adiponectin**

Reference	Participants	Type	Intensity	Volume	Adiponectin (ug/mL)		BW (kg) or % Fat $\Delta$	
					Change	P		P
Kriketos et al. 2004 (74) ††	19 M overweight	Walking/jogging	55-70% VO <sub>2max</sub>	40 min 4-5 d/wk 10 weeks	+9.4	<.001	-0.8 kg	0.08
Hsied & Wang 2005 (53)	42 M 60 F	Walking/jogging	55-74% VO <sub>2max</sub>	20 min every day 52 weeks	+1.4 Y +2.3 O	0.04 0.03	-2.8 % -8.0 %	0.02 0.01
Oberback et al. 2006 (101) ††	20 NGT 20 IGT 20 T2D	Cycling/running Power training Swimming		120 min 4 d/wk 4 weeks	0.0 NGT +2.1 IGT +2.4 T2D	NS <.001 <.001	-1.4 kg -3.2 kg -1.6 kg	<0.05 <0.05 <0.05
Blüher et al. 2006 (9) ††	20 NGT 9M 11F 20 IGT 9M 11F 20 T2D 11M 9F	Cycling/running Swimming		60 min 4 d/wk 4 weeks	+1.1 NGT +3.3 IGT +3.0 T2D	<.001 <.001 <.001	-2.0 kg -3.7 kg -1.7 kg	<0.01 <0.05 <0.001
Ring-Dimitrio et al. 2006 (112)	22 M 14 F obese / sedentary	Cycle ergometer	50% VO <sub>2max</sub> + 5% /week	45 min 3 d/wk 52 weeks	+1.7 12 +0.8 M 24 +2.9 F 12 +2.1 F 24	<0.05 NS NS NS	-1.0 kg -1.2 kg -0.2 kg -1.4 kg	NS NS NS NS
Hulver et al. 2002 (56) ††	11 M 14 F sedentary/obese	Walking/running Cycling/climbing	65-80% VO <sub>2max</sub>	45 min 4 d/wk 24 weeks	+0.3 Ex +9.2 MO	NS <0.05	-0.3 kg -56.6 kg	NS <0.05
Yatagai et al. 2003 (142) ††	12 M healthy no active	Cycle ergometer	Lactate threshold	60 min 5 d/wk 6 weeks	0.0 1wk -3.7 16hr	NS <0.05	0.0 %	NS
O'Leary et al. 2006 (100) ††	5 M 11 F Obese/ sedentary	Treadmill Cycle ergometer Handball	65-85% HR <sub>max</sub>	60 min 5 d/wk 12 weeks	-0.3	NS	-3.2 kg	<0.001
Jürimäe et al. 2006 (63) ††	11 M elite rowers	Water rowing Strength training		24 weeks	+0.9	NS	+0.6 kg	NS

M = male; F = female; NS = not statistically significant; 12 = 12 months of exercise training; 24 = 24 months of exercise training; NGT = normal glucose tolerance; IGT = impaired glucose tolerance; T2D = Type 2 diabetes mellitus; min = minutes; Y = younger; O = older; Ex = exercise group; MO = morbidly obese group; 1wk = one week after training; 16h = 16 hours after training. †† = insulin sensitivity improved and/or fasting insulin decreased; BW = body weight in kg; % fat = body fat expressed as a % of total body weight.

Reseland et al. (110) investigated the effect of a one-year program to reduce body weight by diet alone, exercise alone, and the combination of both to determine changes in leptin concentrations and insulin sensitivity in 186 males with MetS. Body weight and body fat were

reduced more so than diet or exercise alone and insulin sensitivity was improved to a greater extent with the combination of diet and exercise than by diet alone or exercise alone. Similarly, leptin concentrations decreased to a greater extent with the combination of diet and exercise than the other two therapies. The authors concluded that long-term weight loss by reducing dietary intake and/or increasing energy expenditure with exercise reduced leptin concentrations.

Ishii and colleagues (58) investigated the leptin responses to 6 weeks of weight loss and exercise training in sedentary individuals with type 2 diabetes mellitus. The exercise group walked and cycled for 60 minutes 5 days per week at 50% of  $\dot{V}O_{2\max}$  and they maintained a daily caloric intake of 25 to 27 kcal/kg hypo-caloric diet. The control group consumed the same diet, but did not exercise. Body weight, body fat, and fasting insulin did not significantly change with any treatment after training. Leptin concentrations were 36% lower in the exercise group but were not altered in the control group. It appears that repeated bouts of exercise may influence the decreased in leptin in the absence of weight loss.

Leptin concentrations do not always change with exercise training in sedentary lean or obese individuals or in young athletes (51, 97). In sedentary men, leptin concentration was unaltered after 7 consecutive days of moderate-intensity cycle ergometry for 60 minutes per day at 75% of  $\dot{V}O_{2\max}$  (51). Noland et al. (97) investigated the effect of increasing exercise training volume in 9 young male and 12 female competitive college swimmers who trained for 9 weeks. Fasting plasma leptin was obtained at a baseline exercise volume of 27,000 meters per week, and again when exercise training volume increased by 12,000 meters to 39,000 per week and finally by 15,200 to 42,200 meters per week. Leptin concentrations remained unchanged after increased training volume in these swimmers.

In summary, decreases in leptin concentrations with exercise training ranged from 15% to 36%. It appears that sedentary obese and T2D individuals are those who showed higher changes

after exercise training. Most studies in which leptin decreased with exercise training, body weight and/or body fat also decreased. Because weight loss accompanies changes with exercise training, it is hard to determine which these factors: exercise induced weight-loss, diet induced weight loss or the combination of both interventions are the primary influence in changes on leptin concentrations or tissue sensitivity. There is also inconsistent evidence relating the changes in leptin concentrations with exercise training and improvements in insulin sensitivity. It is possible that the decrease in leptin concentrations with exercise may reflect an increased sensitivity of the tissues to leptin (21). Individuals with MetS are already insulin resistance and possibly are leptin resistance as well. Thus, a decrease in leptin concentrations with aerobic exercise may indicate that the restore the sensitivity of skeletal muscle for leptin, is, at least somewhat, restored. The enhanced skeletal muscle leptin sensitivity may help to improve insulin sensitivity (21). Few studies reported the timing of blood samples after the last exercise session, so the decreases in leptin concentrations after exercise training may be a result of the last bout of exercise and not necessarily due to a training adaptation. See table 4.

### **Acute Adipokine Responses to Exercise**

#### *Acute Adiponectin Responses to Exercise*

Kraemer and colleagues (72) was one of the first groups to investigate the adiponectin response to a single session of exercise. The participants were 6 young-healthy males who ran for 30 minutes at an average intensity of 79% of  $\dot{V}O_{2max}$ . Adiponectin concentrations were measured before, immediately after, and 30 minutes post-exercise. Adiponectin concentrations were significantly increased after exercise; however when corrected for plasma volume changes that are known to transiently occur with exercise, the change in adiponectin was no longer significant. Similarly, Ferguson et al. (26) found that the plasma volume-adjusted adiponectin

concentrations remained unaffected by stationary cycling for 60 minutes at 65% of  $\dot{V}O_{2max}$  in 16 normal-weight moderately active men and women.

**Table 4. Effect of Exercise Training on Leptin**

Reference	Participants	Type	Intensity	Volume	Leptin (ng/mL)		BW (kg) or % Fat $\Delta$	
					Change	P		P
Perusse et al. 1997 (107)	51 M 46 F	Cycle ergometer	55-75% $\dot{V}O_{2max}$	30 to 50 min 20 weeks	-0.7 M +0.5 F	0.004 NS	-1.3% -0.5%	<0.001 NS
Pasman et al. 1998 (106) ††	15 M obese	Running/cycling Swimming	Moderate/high	60 min 3-4 d/wk 16 months	-2.1	<0.05	-5.8 kg	<0.05
Halle et al. 1999 (43) ††	20 M obese and T2D	Cycle ergometer Hiking Swimming	70% $HR_{max}$	30 min 5 d/wk 4 weeks	-2.3	<0.001	-4.1 kg	<0.001
Ishii et al. 2001 (58)	50 T2D 20 M 30 F Sedentary	Walking/cycling	50% $\dot{V}O_{2max}$	60 min every day 6 weeks	-2.6	<0.05	-2.8 kg	NS
Reseland et al. 2001 (110) ††	186 M MetS	Walking/jogging Aerobics/ circuit training	85% $HR_{max}$	60 min 3 d/wk 52 weeks	-0.7 D -0.4 Ex -2.2 D&E	<0.05 NS <0.001	-1.4% -1.0% -2.4%	<0.05 <0.001 <0.001
Thong et al. 2000 (125)	52 M obese	Walking/jogging	75% $\dot{V}O_{2max}$	700 kcals Every day 12 weeks	-3.7 DWL -5.1 EWL -0.9 EWS	<0.05 <0.05 NS	-7.7 kg -7.5 kg -0.6 kg	<0.05 <0.05 NS
Houmard et al. 2000 (51) ††	16 young 7 M 9 F 14 older 6 M 8 F Sedentary	Cycle ergometer	75% $\dot{V}O_{2max}$	60 min every day 7 days	+0.5 Y -3.2 O	NS NS	+0.1%	NS
Noland et al. 2001 (97)	9 M swimmers 12 F swimmers	Swimming		High 33,000 m/week	+0.2 M -1.8 F	NS NS	NS -2.5%	NS <0.05

M = male; F = female; NS = not statistically significant; T2D = Type 2 diabetes mellitus; MetS = metabolic syndrome; D = diet; Ex = exercise; D&E = diet and exercise; d/week = days per week; m/week = meters per week; min = minutes; DWL = diet induced weight loss; EWL = exercise induced weight loss; EWS = exercise weight stable; Y = young; O = older; †† = insulin sensitivity improved and/or fasting insulin decreased; BW = body weight in kg; % fat = body fat expressed as a % of total body weight.

Jamurtas and co-workers (59) examined the adiponectin response to a single bout of stationary cycling at an intensity of 65% of  $\dot{V}O_{2max}$  for 45 minutes in 9 overweight males. Plasma volume corrected was unchanged after exercise. However, fasting insulin concentrations decreased and markers of insulin sensitivity improved after exercise. In a similar study design, Numao et al. (98) reported that total and HMW adiponectin concentrations in 8 healthy normal weight males remained unchanged during exercise and for 30 minutes after completing stationary cycling. Similarly, Bobbert et al. (10) observed that total adiponectin, LMW, MMW, or HMW adiponectin did not improve after a single exercise session of 45-minute of cycle ergometry despite improvements in insulin sensitivity. Neither Numao et al. (98) or Bobbert et al. (10) reported that they corrected adiponectin for plasma volume changes.

A single exercise session may increase adiponectin concentrations (63, 64, 74). Jürimäe and colleagues (63) investigated the effect of a maximal bout of rowing on adiponectin concentrations in 11 elite male crew members. Adiponectin concentrations increased 12% immediately after the exercise bout. The same investigators (64) examined the effect of performing a 6000-meter time-trial on adiponectin concentrations in a similar cohort. The authors reported an 11% decrease in adiponectin immediately after the time-trial but the 30-minute post-exercise adiponectin concentrations were increased by 20% compared with pre-exercise concentrations. The researcher's corrected for plasma volume changes, thus, the difference in the results observed in this study could be explained by the kind of the participants, which were elite rowers with high body mass and low body fat or may be the type of rowing exercise which involves a great amount of muscles working during a highly anaerobic bout.

Kriketos and colleagues (74) examined adiponectin changes over a one week period in which participants completed two or three 45-minute bouts of walking or jogging at an intensity of 55-70% of  $\dot{V}O_{2max}$ . The authors reported a 260% increase in adiponectin concentrations along

with a 16% improvement in insulin sensitivity as measured by hyperinsulinemic-euglycemic clamp 24 to 36 hours after exercise. It is possible that the enormous increase in adiponectin concentration observed in this study could be due to hemoconcentration. However, it is rarely that hemoconcentration last up to 24 to 36 hours after the exercise. So, these findings are unique in the literature and we are a little skeptical about these results. See table 5.

In summary, adiponectin concentrations increased after exercise in only 3 out 9 studies (63, 64, 74). Participants in these studies included overweight individuals and elite rowers. Exercise time ranged from 20 to 45 minutes per session and the intensity ranged from 50 to 100% of their  $\dot{V}O_{2max}$ . The type of exercise included walking, jogging and rowing. When adiponectin concentrations increase after exercise, the change is not correlated with insulin sensitivity. Taken together it is clear that an increase in adiponectin occurs rarely after exercise and, when it does occur, it is not obligatory for the observed transient improvement in post-exercise insulin sensitivity. Given the results of Kraemer et al. (72), Ferguson et al. (26), Jamurtas et al. (59) and Kriketos et al. (74), we cannot rule out that the elevated adiponectin concentrations observed after exercise may reflect hemoconcentration rather than a change in the production or clearance of adiponectin. In addition, since the expression of the adiponectin receptors Adipo 1 and 2 in skeletal muscle has been shown to increased after 3 hours of cycling, it may be possible that the sensitivity of the adiponectin was improved with a single bout of exercise (9).

**Table 5. Effect of Acute Exercise on Adiponectin**

Reference	Participants	Type	Intensity	Volume	Adiponectin ( $\mu\text{g/mL}$ )		P
					Pre	Post	
Kriketos et al. 2004 (74) ††	19 M overweight	Walking/jogging	50-70% $\text{VO}_{2\text{max}}$	45 min 2-3 bouts	7.0 $\pm$ 0.7	18.2 $\pm$ 1.9	<.001
Jürimäe et al. 2005 (64)	10 M elite rowers	Rowing ergometer	Max 6000 m trial		6.2 $\pm$ 9.5	5.5 $\pm$ 8.5 *	<0.05
Jürimäe et al. 2006 (63) ††	11 M elite rowers	Water Rowing			25.5 $\pm$ 7.5	28.5 $\pm$ 4.7 *	<0.05
Kraemer et al. 2003 (72)	7 M healthy	Walking/running	79% $\text{VO}_{2\text{max}}$	30 min	7.5 $\pm$ 1.1	8.2 $\pm$ 1.2 *	NS
Ferguson et al. 2004 (26) ††	8 M 8 F healthy moderately active	Cycle ergometer	65% $\text{VO}_{2\text{max}}$	60 min	M 16.4 $\pm$ 4.5 F 19.3 $\pm$ 2.4	16.2 $\pm$ 8.5 * 17.6 $\pm$ 6.2 *	NS NS
Punyadeera et al. 2005 (109)	19 M active	Cycle ergometer	50% $\text{VO}_{2\text{max}}$	120 min	6.6 $\pm$ 0.8	6.2 $\pm$ 0.7	NS
Jamurtas et al. 2006 (59) ††	9 M overweight obese	Cycle ergometer	65% $\text{VO}_{2\text{max}}$	45 min	3.6 $\pm$ 0.7 3.6 $\pm$ 0.7 3.6 $\pm$ 0.7	3.2 $\pm$ 0.4 * 3.2 $\pm$ 0.8 24 hr* 3.4 $\pm$ 0.8 48 hr*	NS NS NS
Bobbert et al. 2007 (10) ††	8 M healthy	Cycle ergometer	50 W + 25 W every 3 min	45 min	7.4 $\pm$ 0.9	6.6 $\pm$ 0.9	NS
Numao et al. 2008 (98) ††	8 M untrained	Cycle ergometer	50% $\text{VO}_{2\text{max}}$	60 min +30 min rest	Not reported		NS

M = male; F = female; NS = not statistically significant; 24 hr = 24 hours post-exercise; 48 hr = 48 hours post-exercise; min = minutes; \* = corrected for plasma volume changes; W = watts; †† = insulin sensitivity improved and/or fasting insulin decreased.

### *Acute Leptin Responses to Exercise*

When significant changes in leptin concentrations occur after exercise, they are always reported as decreased when compared to pre-exercise values (22, 62, 79, 81). Elias and colleagues (22) examined the effect of a 10- to 12-minute maximal treadmill test on leptin concentrations in 7 sedentary overweight males. The authors reported that leptin decreased by

15% immediately after exercise and remained lower than baseline for up to 120 minutes into recovery. Jürimäe et al. (62) studied leptin responses to 30 minutes of stationary rowing in 13 college male rowers. Leptin concentrations decreased by 22% immediately after exercise and remained reduced up to 30 minutes after exercise without significant changes in insulin concentrations.

Plasma leptin responses to competitive endurance events are known to decrease (79, 81). For instance, Landt et al. (79) reported that leptin decreased by 32% after running a 101-mile ultramarathon. Similarly, Leal-Cerro et al. (81) reported a 10% reduction in leptin after a marathon race in male runners.

Leptin responses to different exercise energy expenditures have also been examined (23). Participants completed exercise sessions of 800 and 1500 kcals in random order by running on a treadmill at 70%  $\dot{V}O_{2max}$ . A delayed decrease in plasma volume-corrected leptin was observed 48 hours after both exercise bouts indicating that 800 kcals may elicit a decrease in leptin concentrations and that more prolonged exercise provides no additional influence on leptin or in the decreases in insulin concentrations observed immediately after exercise (23).

Leptin concentrations do not always respond to exercise (26, 27, 75, 107, 126, 134). Perusse et al. (107) reported that leptin concentrations were unchanged after a maximal treadmill exercise test (10 to 12 minutes) in young healthy men and women. However, Elias et al. (22) observed that leptin decreased after a similar duration and maximal treadmill test in sedentary overweight males. The discrepancies in these studies are possible due to the type of participants or maybe because a delayed response occurred as observed in previous reports after exercise (22, 23). Perusse and colleagues (107) measured plasma leptin immediately after exercise and Elias et al. (22) at 30 to 120 minutes after exercise.



Weltman and colleagues (134) examined the effect of 30 minutes of aerobic exercise at different intensities (below and above lactate threshold) in 7 young males. The caloric expenditure was different in both intensities ranging from 150 to 530 kcal per session and leptin was unaltered after exercise in either intensities. However, Essig et al. (23) observed that leptin concentrations decreased after a single bout of exercise in which 800 kcals were expended with no further reduction at 1500 kcals (23). So, it might be possible that there is a caloric expenditure threshold. Fisher et al. (27) observed that leptin concentrations did not respond to 40 minutes of stationary cycling at 85%  $\dot{V}O_{2max}$  in young sedentary males. Similarly, Ferguson et al. (26) reported unchanged plasma leptin concentrations after 60 minutes of cycle ergometry exercise at 65%  $\dot{V}O_{2max}$  in both men and women.

In summary, 5 out of 9 studies have reported that leptin concentration decreases after single exercise session. Participants in these studies included elite athletes, moderately-trained and sedentary normal-weight and overweight individuals. Exercise time ranged from 10 minutes to 4 hours and the intensities reported ranged from 70 to 100% of their  $\dot{V}O_{2max}$ . The type of exercise included running, cycling and rowing. It appears that leptin concentrations decrease more often after competitive endurance events, in individuals with higher cardiorespiratory fitness, or after a minimum energy expenditure suggesting a possible caloric expenditure threshold (11, 23, 55). Some investigators reported the timing of the blood sample immediately post exercise and in recovery periods ranged from 30 minutes to 48 hours (22, 23, 27, 62, 107, 134). As with adiponectin, few researchers reported that they corrected for plasma volume changes (23, 27, 62, 107). Thus, any plasma volume changes after exercise may have an effect on our ability to interpret changes in adipokine concentrations. See table 6.

**Table 6. Effect of Acute Exercise on Leptin**

Reference	Participants	Type	Intensity	Volume	Leptin (ng/mL)		P
					Pre	Post	
Landt et al. 1997 (79)	12 M	Cycle ergometer	75% VO <sub>2max</sub>	4 hrs	2.85 ± 1.5	2.61 ± 1.5	< 0.05
	14 M runners	Ultramarathon run (101 miles)		36 hrs	2.64 ± 0.9	1.80 ± 0.4 <b>UL</b>	< 0.05
Leal-Cerro et al. 1998 (81)	29 M runners	Marathon		3 hrs	2.9 ± 0.2	2.6 ± 0.2	< 0.05
					5.1 ± 0.6		
Elias et al. 2000 (22)	7 M sedentary overweight	Treadmill	Maximal test	10-12 min	Not reported ↓ 15% after exercise until 120 min recovery		< 0.01
Essig et al. 2000 (23) ††	11 M moderately trained	Treadmill	70% VO <sub>2max</sub>	800 kcals	2.6 ± 0.5	2.0 ± 0.3 48 hr*	< 0.05
				1500 kcals	2.7 ± 0.5	2.1 ± 0.3 48 hr*	< 0.05
					2.6 ± 0.5	2.5 ± 0.4 800k*	NS
					2.7 ± 0.5	2.9 ± 0.6 1500k*	NS
Jürimäe et al. 2005 (62)	13 M elite rowers	Rowing ergometer	Maximal rowing	30 min	2.7 ± 0.6	2.1 ± 0.8 *	< 0.05
					2.7 ± 0.6	2.0 ± 0.9 30 min*	< 0.05
Perusse et al. 1997 (107)	51 M 46 F untrained	Cycle ergometer	Maximal test	10-12 min	4.6 ± 4.4	4.7 ± 4.5 M*	NS
					11.9 ± 8.5	11.7 ± 8.0 F*	NS
Welman et al. 2000 (134)	7 M young	Treadmill	Below and above LT	30 min	Not reported		NS
Fisher et al. 2001 (27) ††	8 M young sedentary	Cycle ergometer	85% VO <sub>2max</sub>	41 min	Not reported *		NS

M = male; F = female; NS = not statistically significant; 800k = 800 kcals expended; 1500k = 1500 kcals expended; UL = ultramarathon group; 30 mi = 30 minutes post exercise; 48 hr = 48 hours post exercise; LT = lactate threshold; \* = corrected for plasma volume changes; min = minutes; †† = insulin sensitivity improved and/or fasting insulin decreased.

### Factors that Influences Adipokine Responses to Exercise

The timing of blood samples in relation to the last bout of exercise and corrections for plasma volume changes may have an influence on the interpretation of adipokine responses (9, 22, 23, 59, 72, 74). Adiponectin concentrations have been reported as increased immediately

after exercise and for up to a day and half after exercise (63, 74). Leptin has been reported as decreased immediately after and for up to 2 days after exercise (23). In the exercise training literature few researchers have reported the timing of the blood sample after the last exercise session (9, 51, 100, 142). Blood samples after the last bout of exercise were obtained at 15, 16, 17, 18, and 48 hours or one-week following the last exercise training session (9, 51, 100, 142). If blood samples are taken within 48 hours after the last bout of exercise and a change in these adipokines occur, these changes may be attributed to a transient response to exercise and not to a training adaptation.

Adipokine concentrations unadjusted for plasma volume changes were significantly altered after exercise and, when they were corrected for plasma volume changes, were no longer significant (64, 72). Decreases in plasma volume ranging from 5 to 10% after exercise have been reported previously (62, 64, 72). For instance, Kraemer et al. (72) reported that adiponectin increased almost 10% but with a plasma volume contraction of 8.5% after exercise. When corrected for the plasma volume change the increase in adiponectin was no longer significant after exercise.

Other factors such as the type of analysis such as radioimmunoassay (RIA) or enzyme-linked immunosorbent assay (ELISA) were utilized for the biochemical analysis of these adipokines. Differences in the technique and manufacturing may affect our ability to interpret results after exercise (8). Most researchers report using RIA kits from Linco Research, St. Charles MO (22, 23, 26, 43, 51, 56, 58, 62, 63, 72, 74, 81, 97, 101, 106, 107, 110, 134, 142). Linco Research ELISA kits for the biochemical analysis of adiponectin has been shown to be highly reproducible versus other vendors (8). Other factors that may influence our interpretation of adipokines responses to exercise included the amount of outside physical activity participation

and dietary control before and during the entire study and these factors are seldom reported in the literature (11, 121).

In summary, equivocal results on adiponectin and leptin responses to exercise have been reported in the literature. It appears from these studies that the timing of the blood sample in relation to the last bout of exercise and whether these measurements were corrected or not for plasma volume-shifts may influence the results. Moreover, plasma volume unadjusted adipokines can lead to spurious conclusions and the timing of the blood sample can lead to inconsistencies regarding the adaptations to exercise training or acute responses to episodes of exercise.

### **Summary**

The worldwide prevalence of MetS is increasing rapidly (38). Regular moderate-intensity exercise such as brisk walking, jogging, biking, swimming, for at least 30 minutes and preferably longer of continuous or intermittent bouts on most days of the week have been recommended to help manage MetS and to improve cardiorespiratory fitness (40). Exercise appears to consistently improve insulin sensitivity in healthy individuals and in those with impaired fasting glucose, insulin resistance, and type 2 diabetes mellitus (47, 113). Exercise-induced improvements in glucose uptake and insulin sensitivity may be mediated, in part, by altering adiponectin and leptin. At present, it appears that there is contradictory information regarding adipokine responses to exercise and the adaptations to exercise training. It is clear that exercise may exert an influence on metabolic pathways that increase adiponectin and decrease leptin. Results from this study will help to clarify the effect of exercise on adipokine responses to a single session and multiple sessions of exercise in sedentary obese males with MetS. It will provide information about possible confounding factors such as timing of the blood sample, plasma volume changes, outside physical activity, dietary control and weight loss that may occur after exercise.

## CHAPTER III

### METHODS

#### Overview

Serum samples, collected as part of a previous study that examined lipid and lipoprotein responses to repeated bouts of moderate exercise on successive days, were analyzed for total and HMW adiponectin, leptin, NEFAs and clinical markers for insulin sensitivity.

Fasting blood samples were obtained after one week on a stable diet. All blood samples were collected just prior to exercise on days 1 through 4. Daily exercise involved walking on a treadmill at 60 to 70% of  $\dot{V}O_{2\text{ max}}$  until 350 kcals of energy were expended. Blood was collected again 24 and 72 hours after the last exercise session (see Figure 1).

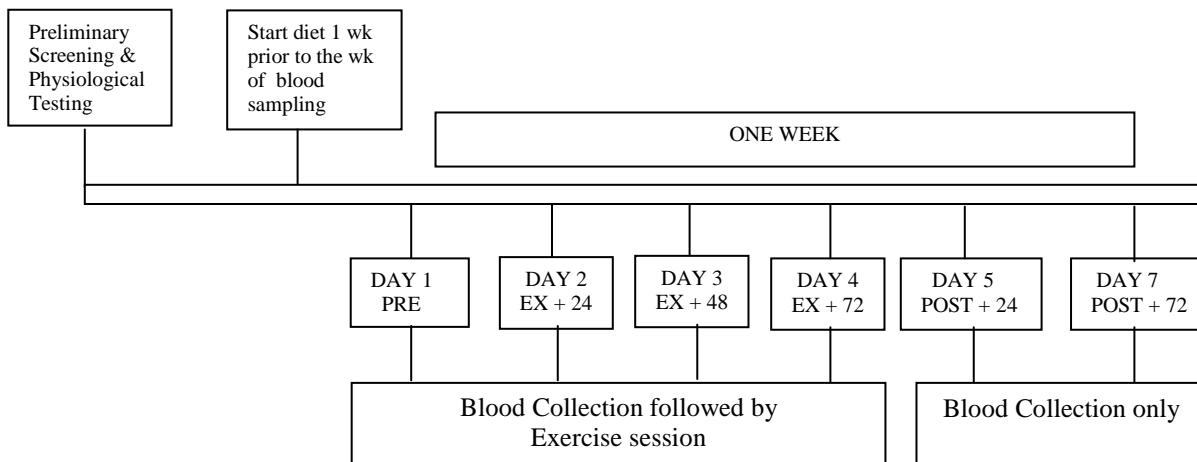

**Fig 2. Schematic of the Experimental Protocol.** Day 1 PRE = pre-exercise blood drawn, Day 2 Ex + 24 = blood drawn 24-hrs post exercise and second exercise session, Day 3 Ex + 48 = 48-hrs post-exercise blood drawn and third exercise session, Day 4 Ex + 48 = 72-hrs post exercise blood drawn and fourth exercise session, Day 5 Post + 24 = blood drawn 24-hrs after the last exercise session, Day 5 Post + 72 = blood drawn 72-hrs after the last exercise session. This schematic is redrawn from reference (37).

## **Participants**

For the original investigation, sedentary middle-aged male volunteers with dyslipidemia were recruited. Volunteers had to be non-smokers and not currently taking drugs known to alter glucose or lipid metabolism or taking antihypertensive agents. Fifteen participants met all criteria and were screened by a physician prior to undergoing preliminary physiologic testing.

Anthropometric measurements and an exercise stress test were used to determine body composition and cardiovascular fitness. Samples from eleven participants were available for biochemical analysis of all variables of interest.

## **Blood Sampling Procedures**

Participants reported to the laboratory in a fasting state for each of the blood samples. Blood samples were drawn into two (10-ml) red-top vacutainer tubes (Becton Dickinson Vacutainer Franklin lakes, NJ, 13 x 100 mm). Hemoglobin concentrations and hematocrit were measured immediately after blood samples were obtained in order to estimate plasma volume shifts that are known to transiently occur with exercise (19). Blood samples were allowed to clot for at least 30 minutes and then centrifuged at 1500 x g for 10 minutes. Serum was then aliquotted and stored at -70° C for future analysis.

## **Biochemical Analysis**

Total and HMW adiponectin, leptin, and insulin concentrations were determined by enzyme-linked immunosorbent assay (ELISA) (Millipore, St. Charles, MO). Briefly, the ELISA procedure consists of a two-antibody sandwich ELISA which is used to determine the antigen concentration in unknown samples. This assay requires two-antibodies that bind to epitopes that do not overlap on the antigen. The captured antibody binds to the plate. The antigen is added and allowed to bind with the antibody. The unbound products are removed with a wash and a second labeled antibody is allowed to bind to the antigen. The assay quantifies the variable of interest by

measuring the amount of the antibody remaining on the plate (Millipore Corporation, Linco Research, St. Charles, MO).

NEFAs and glucose concentrations were estimated by enzymatic colorimetric assays (Wako Diagnostics, Richmond, VA). All samples from a participant were assayed in a single run in order to eliminate the inter-assay coefficients of variation. The homeostasis model assessment (HOMA) is a clinical marker of insulin resistance (90). HOMA was calculated from fasting insulin and glucose concentrations as follows:  $[\text{fasting insulin } (\mu\text{U/mL}) \times \text{fasting glucose (mmol/L)}] / 22.5$  (90).

### **Statistical Analysis**

The independent variable was blood sample time (samples obtained days 1 through 5 and day 7). The dependent variables of interest were plasma volume-adjusted concentrations of total and HMW adiponectin, leptin, insulin, glucose, and NEFAs. Tests for normality on baseline distributions for each dependent variables were conducted using the Kolmogorov-Smirnov test (85). Leptin concentration, the only variable exhibiting a leptokurtotic distribution, was normalized using a  $\log_{10}$  transformation. Variables of interest were analyzed using multiple 1 x 6 repeated measures ANOVAs. Duncan's New Multiple Range tests were employed to further explore significance determine by ANOVA. Pearson product-moment correlation coefficients were used to determine the relationship between baseline physiological characteristics and changes in plasma volume-adjusted variables that occurred with exercise and the changes observed during the 3-days of recovery following the last exercise session. All data were analyzed using the Statistical Analysis System (SAS version 9.1; SAS Institute, Cary, NC). Because this study was exploratory in nature a comparison-wise error rate was set at  $p < 0.05$ .

## CHAPTER IV

### RESULTS

#### Baseline Physiological Characteristics

The baseline physiological characteristics and blood variables of fifteen middle-aged obese participants are described on Tables 7 and 8.

**Table 7. Baseline Physiological Characteristics**

<i>Physical Characteristics</i>	<i>Mean ± SD</i>	<i>Minimum</i>	<i>Maximum</i>
Age (years)	50 ± 8.0	37	67
Height (cm)	178 ± 6.0	167	188
Weight (kg)	101 ± 18.0	67	127
BMI (kg/m <sup>2</sup> )	32.0 ± 4.6	23	40
% Fat (% of weight)	29 ± 4.0	19	34
$\dot{V}O_2$ (L min <sup>-1</sup> )	2.89 ± 0.4	2.1	3.7
$\dot{V}O_{2max}$ (ml kg <sup>-1</sup> min <sup>-1</sup> )	28.9 ± 4.3	22	36
SBP (mmHg)	140 ± 8.6	126	154
DBP (mmHg)	92 ± 6.3	78	104
<i>Blood Characteristics</i>			
Cholesterol (mg/dL)	253 ± 44.0	194	333
LDL-C (mg/dL)	168 ± 42.0	103	257
HDL-C (mg/dL)	32 ± 5.0	25	44
TG (mg/dL)	267 ± 145.0	45	494
NEFA (mEq/L)	1.34 ± 0.49	0.96	2.75
Glucose (mg/L)	99.6 ± 12.8	80.3	131.9
Insulin (μU/mL)	15.5 ± 10.0	3.7	36.2
HOMA score	3.92 ± 2.78	1.06	9.32
Adiponectin (μg/mL)	5.7 ± 2.1	3.2	9.9
HMW adiponectin (μg/mL)	2.8 ± 1.0	1.4	4.6
Leptin (ng/mL)	20.9 ± 12.3	9.3	47.5

All values are presented as means ± standard deviation along with minimum and maximum values that define the range. BMI = body mass index;  $\dot{V}O_{2max}$  = maximal oxygen consumption in liters per minute;  $\dot{V}O_{2max}$  = maximal oxygen consumption milliliters per kilogram per minute; SBP = systolic blood pressure; DBP = diastolic blood pressure; LDL-C = low density lipoprotein cholesterol; HDL-C = high density lipoprotein cholesterol; TG = triglyceride; NEFA = non-esterified fatty acid; HOMA score = homeostasis model score; HMW adiponectin = high molecular weight. Concentrations were determined from plasma.



**Table 8. Participants Meeting Criteria for Metabolic Syndrome**

<i>Variable</i>	<i>NCEP Criteria for Elevated CVD Risk</i>	<i>Frequency</i>	<i>Percentage</i>
Total Cholesterol or LDL-C	>200 mg/dL or >130 mg/dL	15/15	100%
HDL-C	< 40 md/dL	13/15	87%
Triglyceride	≥150 mg/dL	12/15	80%
Glucose	≥100 mg/dL	6/15	40%
SBP	≥140 mmHg	13/15	87%
BMI	≥ 30 kg/m <sup>2</sup>	12/15	80%
Those with elevated cholesterol and meeting ≥3 NCEP-MetS criteria		14/15	93%

All values are presented as the number of participants meeting criteria threshold and as a percentage from 15 participants. NCEP = National Cholesterol Education Program; HDL-C = high density lipoprotein cholesterol; SBP = systolic blood pressure; DBP = diastolic blood pressure; BMI = body mass index; MetS = metabolic syndrome.

Plasma volume changes with exercise, relative to the baseline estimate, ranged from 1% to > 11%. However, the plasma volume shifts occurring with exercise and the recovery period were not significantly different ( $p = 0.07$ ,  $F_{5,6} = 2.18$ ). We present plasma volume adjusted and unadjusted results because even small, statistically insignificant, fluctuations in plasma volume may change our interpretation of how exercise influences blood concentration variables.

#### **Clinical Markers of Insulin Sensitivity (unadjusted for plasma volume changes)**

Average plasma glucose concentrations were not altered after several bouts of aerobic exercise ( $p = 0.13$ ,  $F_{5,6} = 1.77$ ). However, mean insulin concentrations and the HOMA scores decreased after one exercise session ( $p = 0.02$ ,  $F_{5,6} = 2.95$ ) and ( $p = 0.04$ ,  $F_{5,6} = 2.51$ ) for all variables. NEFA concentration remained unaltered with exercise and through most of the recovery period; however, NEFA concentration was 17% lower than baseline concentrations 72 hours post-exercise ( $p = 0.04$ ,  $F_{5,6} = 2.45$ ). The clinical marker responses to exercise and recovery are provided in Table 9.

**Table 9. Clinical Markers of Insulin Sensitivity (unadjusted for plasma volume changes): Responses to Exercise and Recovery**

<i>Variable</i>	<i>Baseline</i>	<i>Day 2</i>	<i>Day 3</i>	<i>Day 4</i>	<i>24-post</i>	<i>72-post</i>
NEFA (mEq/L)	1.34 ± 0.15 <sup>a</sup>	1.54 ± 0.17 <sup>a</sup>	1.28 ± 0.14 <sup>a</sup>	1.56 ± 0.15 <sup>a</sup>	1.40 ± 0.15 <sup>a</sup>	1.11 ± 0.08 <sup>b</sup>
Glucose (mg/L)	99.6 ± 3.3 <sup>a</sup>	96.1 ± 2.5 <sup>a</sup>	101.8 ± 2.9 <sup>a</sup>	101.7 ± 3.7 <sup>a</sup>	102.9 ± 2.9 <sup>a</sup>	104.7 ± 3.2 <sup>a</sup>
Insulin (μU/ mL)	15.5 ± 2.6 <sup>a</sup>	11.5 ± 1.7 <sup>b</sup>	10.4 ± 1.1 <sup>b</sup>	12.3 ± 1.9 <sup>ab</sup>	9.3 ± 0.1 <sup>b</sup>	11.9 ± 1.9 <sup>b</sup>
HOMA score	3.92 ± 0.72 <sup>a</sup>	2.77 ± 0.44 <sup>b</sup>	2.61 ± 0.33 <sup>b</sup>	3.06 ± 0.53 <sup>ab</sup>	2.32 ± 0.26 <sup>b</sup>	2.99 ± 0.51 <sup>ab</sup>

All values are presented as means ± standard error. Means with the same superscript are statistically similar ( $p > 0.05$ ). NEFA = non-esterified fatty acids; HOMA score = homeostasis model score; QUICKI index = quantitative insulin sensitivity check index.

**Adipokine Concentrations (unadjusted for plasma volume changes)**

Concentrations of adiponectin ( $p = 0.92$ ;  $F_{5,6} = 0.28$ ) and HMW adiponectin ( $p = 0.99$ ;  $F_{5,6} = 0.12$ ) were not altered by exercise. ANOVA results from transformed and non-transformed leptin concentrations were not different; therefore, results for the non-transformed leptin concentration are reported here. A single exercise session lowered the average leptin concentration by 10% and leptin continued to decrease so that concentrations were 26% lower than baseline concentrations after four exercise sessions ( $p < 0.001$ ). Leptin remained lower than the average baseline concentration up to 72 hours after completing exercise. The adipokine responses to exercise and recovery – unadjusted for plasma volume shifts – are described in Table 10 and illustrated in Figure 2.

**Table 10. Adiponectin Concentrations (unadjusted for plasma volume changes)**

<i>Variable</i>	<i>Baseline</i>	<i>Day 2</i>	<i>Day 3</i>	<i>Day 4</i>	<i>24-post</i>	<i>72-post</i>
Adiponectin (μg/mL)	5.66 ± 0.62 <sup>a</sup>	5.68 ± 0.67 <sup>a</sup>	5.86 ± 0.69 <sup>a</sup>	5.95 ± 0.83 <sup>a</sup>	5.66 ± 0.94 <sup>a</sup>	5.55 ± 0.79 <sup>a</sup>
HMW Adiponectin (μg/mL)	2.77 ± 0.31 <sup>a</sup>	2.82 ± 0.41 <sup>a</sup>	2.78 ± 0.35 <sup>a</sup>	2.83 ± 0.44 <sup>a</sup>	2.73 ± 0.40 <sup>a</sup>	2.67 ± 0.34 <sup>a</sup>

All values are presented as means ± standard error. Means with the same superscript are similar ( $p > 0.05$ ). HMW = high molecular weight. Concentrations are reported as μg/mL.

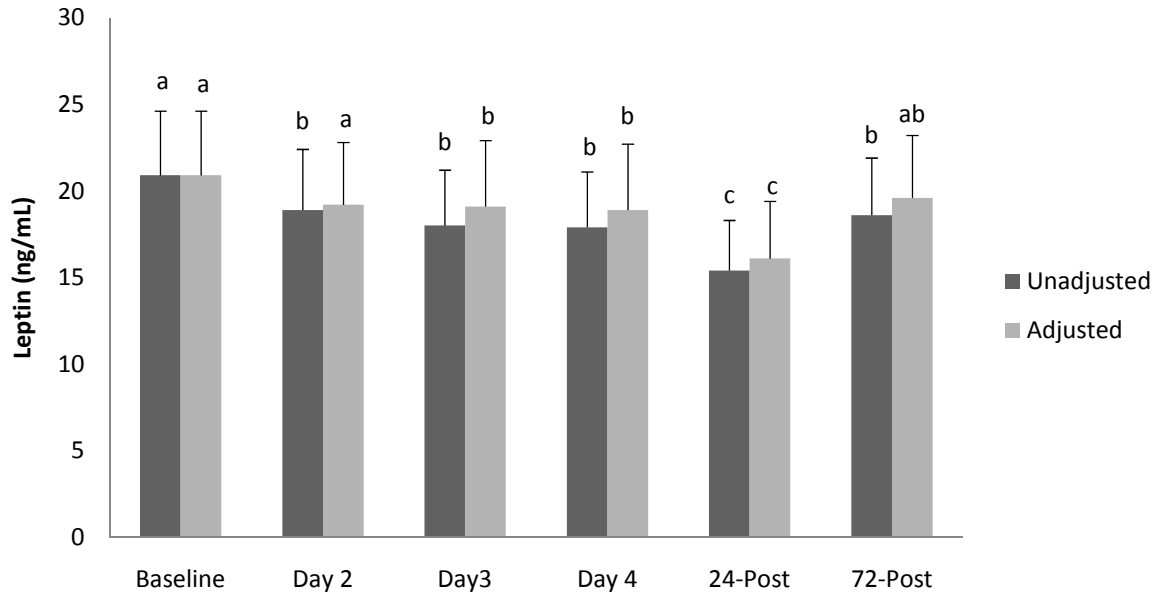

**Fig. 3. Plasma Volume-unadjusted and Adjusted Leptin Responses to Exercise.** All values are presented as means  $\pm$  standard error. Means with the same superscript are similar ( $p > 0.05$ ). Baseline unadjusted ( $20.9 \pm 3.7$ ); Day 2 unadjusted ( $18.9 \pm 3.5$ ); Day 3 unadjusted ( $18.0 \pm 3.2$ ); Day 4 unadjusted ( $17.9 \pm 3.2$ ); 24-hour post unadjusted ( $15.4 \pm 2.9$ ); 72-hour post unadjusted ( $18.6 \pm 3.3$ ). Baseline adjusted ( $20.9 \pm 3.7$ ); Day 2 adjusted ( $19.2 \pm 3.6$ ); Day 3 adjusted ( $19.1 \pm 3.8$ ); Day 4 adjusted ( $18.9 \pm 3.8$ ); 24-hour post adjusted ( $16.1 \pm 3.3$ ); 72-hour post adjusted ( $19.6 \pm 3.6$ ).

### Clinical Markers of Insulin Sensitivity (adjusted for plasma volume changes)

Glucose ( $p = 0.13$ ,  $F_{5,6} = 1.77$ ) and NEFA ( $p = 0.09$ ,  $F_{5,6} = 1.98$ ) concentrations and the HOMA score ( $p = 0.07$ ,  $F_{5,6} = 2.18$ ) were not altered by exercise. However, the average insulin concentration was lowered after one exercise session ( $p < 0.0001$ ;  $F_{5,6} = 118.9$ ) and remained lower than baseline values up to 72 hours after the last exercise session. The plasma volume-adjusted clinical marker responses to exercise and recovery are shown in Table 11.

**Table 11. Clinical Markers of Insulin Sensitivity (adjusted for plasma volume changes)**

Variable	Baseline	Day 2	Day 3	Day 4	24-post	72-post
NEFA (mEq/L)	$1.34 \pm 0.15^a$	$1.56 \pm 0.18^a$	$1.34 \pm 0.17^a$	$1.64 \pm 0.19^a$	$1.47 \pm 0.19^a$	$1.16 \pm 0.09^a$
Glucose (mg/L)	$99.6 \pm 3.3^a$	$96.1 \pm 2.5^a$	$101.8 \pm 2.9^a$	$101.7 \pm 3.7^a$	$102.9 \pm 2.9^a$	$104.7 \pm 3.2^a$
Insulin ( $\mu\text{U}/\text{mL}$ )	$15.5 \pm 2.6^a$	$11.5 \pm 1.7^b$	$10.6 \pm 1.1^b$	$12.9 \pm 2.1^{ab}$	$9.5 \pm 0.1^b$	$12.5 \pm 2.1^{ab}$
HOMA score	$3.92 \pm 0.72^a$	$2.79 \pm 0.44^a$	$2.72 \pm 0.33^a$	$3.41 \pm 0.63^a$	$2.41 \pm 0.26^a$	$3.32 \pm 0.62^a$

All values are presented as means  $\pm$  standard error. Means with the same superscript are similar ( $p > 0.05$ ). NEFA = non-esterified fatty acids; HOMA score = homeostasis model score.

### Adipokine Concentrations (adjusted for plasma volume changes)

The average adiponectin ( $p = 0.36$ ;  $F_{5,6} = 1.12$ ) and adiponectin HMW ( $p = 0.89$ ;  $F_{5,6} = 0.33$ ) concentrations remained unchanged after several sessions of exercise. However, leptin significantly decreased after two bouts of exercise and remained lower than the baseline concentration for up to 24 hours after the last exercise session ( $p = 0.0006$ ;  $F_{5,6} = 5.37$ ). The plasma volume-adjusted adiponectin responses to exercise and recovery are shown in Table 12.

**Table 12. Adiponectin Concentrations (adjusted for plasma volume changes)**

<i>Variable</i>	<i>Baseline</i>	<i>Day 2</i>	<i>Day 3</i>	<i>Day 4</i>	<i>24-post</i>	<i>72-post</i>
Adiponectin ( $\mu\text{g/mL}$ )	$5.66 \pm 0.62^a$	$5.73 \pm 0.68^a$	$6.05 \pm 0.71^a$	$6.19 \pm 0.86^a$	$5.77 \pm 0.87^a$	$5.78 \pm 0.84^a$
Adiponectin HMW( $\mu\text{g/mL}$ )	$2.77 \pm 0.31^a$	$2.87 \pm 0.43^a$	$2.87 \pm 0.36^a$	$2.94 \pm 0.46^a$	$2.78 \pm 0.38^a$	$2.78 \pm 0.36^a$

All values are presented as means  $\pm$  standard error. Means with the same superscript are similar ( $p > 0.05$ ). ADN = adiponectin; HMW = high molecular weight adiponectin.

### Physiological Responses to Exercise

All participants completed four bouts of exercise and the target exercise intensity and duration in each exercise session was met. The exercise oxygen consumption ranged from 15.7 to 24.5  $\text{ml}\cdot\text{kg}\cdot\text{min}^{-1}$  and the exercise heart rate ranged from 115 to 151 beats per minute. The exercise time ranged from 28 to 43 minutes per session. The physiological variables measured from each exercise session are presented in Table 13.

**Table 13. Exercise Session Characteristics**

<i>Variable</i>	<i>Baseline</i>	<i>Day 2</i>	<i>Day 3</i>	<i>Day 4</i>	<i>P-Value</i>
CAL (kcal bout)	$351 \pm 0.7^a$	$351 \pm 1.1^a$	$348 \pm 0.8^{ab}$	$350 \pm 0.3^a$	0.04
TIME ( $\text{min}^{-1}$ )	$34.1 \pm 1.1^a$	$35.0 \pm 1.3^a$	$35.2 \pm 1.3^a$	$34.9 \pm 1.3^a$	0.32
HR ( $\text{beats}\cdot\text{min}^{-1}$ )	$138 \pm 2^a$	$133 \pm 3^a$	$131 \pm 3^b$	$133 \pm 3^b$	<0.001
$\dot{V}\text{O}_2$ ( $\text{L}\cdot\text{min}^{-1}$ )	$2.08 \pm 0.1^a$	$2.05 \pm 0.1^a$	$2.02 \pm 0.1^a$	$2.04 \pm 0.1^a$	0.35

All values are presented as means  $\pm$  standard error. Means with the same superscript are similar ( $p > 0.05$ ). CAL = exercise caloric expenditure; TIME = exercise time; HR = exercise heart rate;  $\dot{V}\text{O}_2$  = absolute oxygen consumption.

## **Correlations**

### *Correlations Among Baseline Variables*

Baseline insulin concentrations were correlated with NEFAs ( $r = 0.66$ ;  $p = 0.03$ ) and NEFAs were correlated with HOMA ( $r = 0.62$ ;  $p = 0.04$ ). There was an inverse correlation between HMW adiponectin and NEFA ( $r = -0.67$ ;  $p = 0.03$ ). Leptin concentrations were correlated with body weight ( $r = 0.71$ ;  $p = 0.01$ ), BMI ( $r = 0.72$ ;  $p = 0.01$ ), percentage of body fat ( $r = 0.69$ ;  $p = 0.02$ ) and NEFA ( $r = 0.72$ ;  $p = 0.01$ ).

### *Correlations Between Baseline Physiological Variables and the Changes in Plasma Volume-Adjusted Variables*

Body weight ( $r = 0.78$ ;  $p = 0.001$ ) and BMI ( $r = 0.88$ ;  $p < 0.001$ ) were correlated with the changes in insulin concentrations after exercise (from 24 to 72 hours after the last episode of exercise). Body weight ( $r = 0.67$ ;  $p = 0.03$ ) and percentage of body fat ( $r = 0.73$ ;  $p = 0.02$ ) were correlated with the change in leptin concentrations over the same period of time.

## **Quality Control**

The intra-assay coefficients of variation were as follows: adiponectin: 2.78%; HMW adiponectin; 4.45%; leptin: 10.28%; insulin: 1.02%; glucose: 0.98%; NEFA: 2.30%. The inter-assay coefficients of variation were as follows: adiponectin 2.72%; HMW adiponectin 2.63%; leptin 3.39%; insulin: 2.20%; glucose: 1.8%; NEFA: 2.36%. Because all samples from a single participant were analyzed in a single assay “run”, inter-assay variation was eliminated as random error.

## **CHAPTER V**

### **DISCUSSION**

Our purpose was to clarify the effect of exercise on adipokine responses in sedentary obese men with MetS. Our primary findings are leptin concentrations may be transiently lowered with exercise, of sufficient volume. It appears that an exercise energy expenditure of between 350 and 700 kcals is adequate to induced decreases in plasma leptin. In regard to leptin concentrations, the accumulated effect of exercise completed on 4 consecutive days was greater than the effect obtained from a two exercise sessions totally 700 kcals. Fasting insulin concentrations decrease with as little as 350 kcals and adiponectin concentrations did not change at all. Together, these results indicate that changes in leptin; but not adiponectin may continue to improve insulin resistance but are not necessary for a post exercise insulin-mediated glucose metabolism to be improved. The decreases in fasting leptin and insulin concentrations after multiple bouts of exercise last up to 24 hours but not longer than what has been observed with a single session (22, 23). The results were slightly different plasma-volume adjusted and plasma-volume unadjusted after exercise in HOMA scores when using fasting insulin and glucose. These results confirm that plasma leptin concentrations and fasting insulin concentrations decreased transiently after exercise without changes in body weight and with or without corrections for plasma volume changes (22, 23, 62). Correcting blood variables for plasma volume after exercise may alter our interpretation of results making plasma volume corrections necessary. Our findings support previous reports in which adiponectin and HMW adiponectin did not increase with a

single or with multiple exercise sessions when changes in body weight and/or body fat did not occur (10, 26, 59, 72, 98, 121).

### **Adipokine Responses to Single Bout of Exercise**

Leptin concentrations were not altered by a single bout of exercise. These results confirm our hypothesis that 350 kcals of exercise energy expended is not enough to decrease leptin concentrations even in sedentary obese men with MetS. We choose 350 kcals because others have shown that this amount of energy expenditure can change other blood markers of metabolic health in these type of participants (20). Our results support previous reports in which leptin concentrations are not affected by a single bout of exercise in sedentary healthy young men (27, 134). Weltman et al. (134) found that 30 minutes of aerobic exercise at caloric expenditures ranging from 150 to 530 kcal per session did not alter leptin concentrations in young males. However, leptin concentrations can decrease when exercise results in high caloric energy expenditure (23, 79, 81). For instance, leptin concentrations decreased after expending 800 kcals running on treadmill in moderately trained men (23). Others reported that leptin concentrations decrease with relatively low calorie expenditure when exercise is at high-intensity (22, 62). Elias et al. (22) observed that leptin concentrations decrease by 15% after a maximal treadmill test in sedentary overweight males. However, Perusse et al. (107) reported that leptin concentrations were unchanged after a maximal treadmill exercise test in young healthy men and women. The discrepancies in these studies are possibly due to the type of participants or maybe due to corrections in plasma volume changes. Perusse and colleagues (107) reported that they corrected leptin for plasma volume changes and Elias et al. (22) did not. It is possible that exercise intensity may have an influence on the exercise response. However, we did not examine the effect of exercise intensity in leptin concentrations. Our participants were obese men with MetS and certainly they can perform a supervised maximal graded exercise test. However from a

practical perspective it is not recommended that these individuals exercise daily at higher intensities because of their excess body weight, low cardiorespiratory fitness and because they are at higher risk of an untoward event during exercise (37). However, we cannot rule out the possibility that exercise intensity may contribute to the decrease in leptin concentrations.

We observed a 26% decrease in fasting insulin concentrations and a non-significant 29% decrease in HOMA score after one exercise session. These results confirm our hypothesis that fasting insulin and HOMA score would be reduced after a single bout of exercise. This is consistent with prior investigations in which fasting insulin concentrations range from 27 to 35% lower and HOMA scores also decrease after a single bout of exercise in healthy, moderately trained and overweight individuals (10, 23, 26, 59).

We found that a single bout of exercise did not increase adiponectin or HMW adiponectin concentrations. These results support our hypothesis and confirm that adiponectin or HMW adiponectin was not altered with exercise in healthy, sedentary and/or obese individuals (10, 26, 59, 72, 98). For instance, adiponectin concentrations, corrected for plasma volume changes, were unchanged after a single bout of moderate-intensity exercise in overweight males (59). Kraemer et al. (72) observed that a single session of exercise increased adiponectin concentrations almost 10% in healthy young men. However, plasma volume decreased by 8.5% after exercise and when adiponectin was corrected for plasma volume changes the increase in adiponectin was no longer significant.

It is possible that the sensitivity of skeletal muscle to adiponectin increased with no changes in plasma adiponectin as previously reported in obese and insulin-resistant individuals (9). The expression of the adiponectin receptors Adipo 1 and 2 in skeletal muscle increased after a single bout of exercise indicating that the tissue sensitivity for adiponectin may improve (9). In the present study, we did not measure adiponectin receptors responses to exercise. Therefore, we



can not exclude the possibility that tissue sensitivity for adiponectin may have improved. Adiponectin concentration responses do not appear with this amount of exercise – and to the extent that a single exercise session improves insulin metabolism – adiponectin concentrations would be a poor marker for such changes.

A single bout of exercise has been shown to improve insulin sensitivity and insulin resistance with and without changes in adiponectin concentrations (10, 26, 59). However, our results and the results of others (26, 64, 109) would support the position that there is at best only a weak association between adiponectin concentrations and changes in insulin sensitivity with exercise.

### **Adipokine Responses to Repeated Exercise**

We found that additional caloric expenditure from two successive exercise sessions totaling 700 kcals decreased leptin concentrations. We hypothesized that leptin concentrations would decrease with additional caloric expenditure resulting from repeated daily exercise. There was not further decreasing in leptin concentrations with additional caloric expenditure from more bouts of exercise suggesting that there is not an additive effect. It appears that somewhere between 350 and 700 kcals is the caloric energy expenditure threshold that may elicit a change in leptin concentrations after exercise. We might suggest this caloric expenditure because the effect of exercise may last up to 24 hours for several humoral variables (20). When we introduced another exercise bout of 350 kcals, the resulting 700 kcals appear to have induced post-exercise decrease in leptin. It should be noted that no further reduction in leptin was observed after 700 kcals. This is consistent with a prior report in which leptin concentrations decreased after a single bout of exercise in which 800 kcals were expended with no further reduction at 1500 kcals (23).

We found that fasting insulin concentrations did not continue decreasing with several bouts of exercise. We hypothesized that repeated exercise sessions reduce clinical markers of

insulin resistance without changes in plasma volume-adjusted adipokine concentrations.

However, the temporary decrease in insulin concentrations may contribute at least, in part, with the decrease in leptin concentrations and maybe with the synthesis of leptin as suggested previously (23). The mechanism by which aerobic exercise lowers leptin concentrations and improves insulin sensitivity is not completely understood, but it appears that the activation of AMPK may contribute at least, in part, with the improvement in insulin sensitivity. Exercise improves the action and sensitivity of leptin in the hypothalamus (28). At least in rats, leptin injections in the hypothalamus of exercising animals increased the hypothalamic phosphorylation of leptin receptor and increased JAK activity to a greater extent than the observed in sedentary animals (28).

It is also possible that with exercise the decrease in insulin concentrations decreases leptin concentrations and may increase the sensitivity of the tissues to leptin in humans. Individuals with MetS are already insulin resistant and possible leptin resistant as well. Increased leptin concentrations occur with body fat accumulation and metabolic dysfunction and are thought to be due to a systemic “leptin resistance” (117). Higher concentrations of leptin have been directly correlated with the degree of obesity (88) and with MetS independent from obesity (31), where leptin concentrations are elevated and leptin transporters and receptors are impaired (5). The chronically-elevated leptin concentrations stimulate a pro-inflammatory response by increasing the macrophage production of tumor necrosis factor alpha (TNF- $\alpha$ ) and interleukin-6 (IL-6). These cytokines are implicated in inflammation, insulin resistance, and atherosclerosis (6, 84). Leptin concentrations decrease with weight loss in obese individuals (50, 114, 116). The lowering of blood leptin concentrations that occur with weight loss may be reflective of an enhanced target tissue sensitivity (106). Thus, exercise may improve the sensitivity of skeletal muscle for leptin and in turn, activate AMPK, increase glucose uptake and decrease the lipid

content in the cell promoting GLUT-4 translocation to the cell surface and improve insulin sensitivity (21). However, these exercise benefits can also occur in healthy individuals. Decreases in leptin concentrations and improvements in insulin sensitivity after exercise have been observed in healthy, lean, moderately trained and obese individuals (23, 43, 110). Furthermore, changes in leptin concentrations have been associated with changes in insulin sensitivity, suggesting that improve leptin sensitivity is related to improved insulin-mediated glucose uptake (23).

We found that several repeated bouts of exercise did not decrease adiponectin or HMW adiponectin concentrations. We hypothesized that adiponectin concentrations would increase with additional caloric expenditure resulting from repeated daily exercise. Our results are in contrast with a previous report in which two-to-three bouts of aerobic exercise performed within a week increased adiponectin concentrations in overweight individuals (74). However, it seems from the current literature that adiponectin concentrations increase more often when body weight or body fat decrease in sedentary, obese, impaired glucose and in type 2 diabetic individuals (9, 53, 101, 112).

### **Accumulated Effect of Multiple Bouts of Exercise**

We found that the accumulated effect from multiple bouts of exercise decreased leptin concentrations by 23% and this benefit was greater than the 9% decreased in leptin concentrations observed after two bouts further support for energy expenditure thresholds and that caloric expenditure is a stimulus for changes this energy balance signal. This effect lasts up to 24 hours after the last bout of exercise. These results are in contrast with our hypothesis that decreases in leptin concentrations may persist for a greater period of time after exercise than what is observed after a single exercise bout. When leptin concentrations decreased with exercise, these responses are also transient (22, 23). Decreases in leptin concentrations have been

observed to last between 30 and 120 minutes after maximal exercise (22) and to persist for up to 48 hours after exercise (23).

In the exercise training literature few researchers have reported the timing of the blood sample after the last exercise session (9, 51, 100, 142). Blood samples after the last bout of exercise were obtained between 12, to 96 hours or one-week following the last exercise training session (9, 51, 100, 125, 142). If blood samples are taken within 48 hours after the last bout of exercise and a change in these adipokines occur, these changes may be attributed to a transient response to exercise and not to a training adaptation.

Relatively rapid metabolic responses to a single bout or accumulated exercise over several days may elicit similar changes in insulin resistance and adipokine concentrations that are often reported as adaptations to exercise training. Thus, improvements in metabolic health can occur with just one or two sessions of exercise without changes in body weight or body composition, even in men with MetS, and maintained with repeated exercise rather than potentiated with each successive exercise bout. The effect of four bouts of exercise imparts a decrease in plasma leptin and improves insulin sensitivity that may be contributory to changes in insulin resistance that can last for up to 24-hour after the last bout of exercise.

### **Summary and Conclusions**

In summary, we found that plasma leptin concentrations are transiently reduced in obese men with metabolic syndrome and this reduction was maintained up to 24 hours after exercise. Adiponectin and HMW adiponectin were unaltered by exercise. No further change in adipokines and markers of metabolic health were observed after exercise repeated on successive days. It seems that the accumulated energy expenditure due to repeated bouts of exercise on successive days imparts a greater leptin response beyond that of two exercise sessions.

The changes in leptin concentrations after exercise may occur without changes in body weight or body composition. It is critical to adjust blood variables of interest for plasma volume fluctuations that occur with exercise.

Our results are consistent with the current general exercise recommendations from the American College of Sports Medicine and the American Heart Association of daily moderately-intense aerobic exercise in order to promote and maintain health (46).

## REFERENCES

1. **Aaronson DS, and Horvath CM.** A road map for those who don't know JAK-STAT. *Science* 296: 2002.
2. **Alberti KG, Eckel RH, Grundy SM, Zimmet PZ, Cleeman JI, Donato KA, Fruchart JC, James WP, Loria CM, and Smith SC.** Harmonizing the Metabolic Syndrome: A joint Interim Statement of the International Diabetes Federation Task Force on Epidemiology and Prevention; National Heart, Lung, and Blood Institute; American Heart Association; World Heart Federation; International Atherosclerosis Society; and International Association for the Study of Obesity. *Circulation* 120: 1640-1645, 2009.
3. **Alberti KG, and Zimmet PZ.** Definition, diagnosis and classification of diabetes mellitus and its complications. Part 1: diagnosis and classification of diabetes mellitus provisional report of a WHO consultation. *Diabetes Med* 15: 539-553, 1998.
4. **Assmann G, Guerra R, Fox G, Cullen P, Schulte H, Willett D, and Grundy SM.** Harmonizing the definition of the metabolic syndrome: comparison of the criteria of the Adult Treatment Panel III and the International Diabetes Federation in United States American and European populations. *Am J Cardiol* 99: 541-548, 2007.
5. **Banks WA, Coon AB, Robinson SM, Moinuddin A, Shultz JM, Nakaoke R, and Morley JE.** Triglycerides induce leptin resistance at the blood-brain barrier. *Diabetes* 53: 1253-1260, 2004.
6. **Bastard JP, Maachi M, Lagathu C, Kim MJ, Caron M, Vidal H, Capeau J, and Feve B.** Recent advances in the relationship between obesity, inflammation, and insulin resistance. *Eur Cytokine Netw* 17: 4-12, 2006.
7. **Berneis K, Vosmeer S, and Keller U.** Effects of glucocorticoids and of growth hormone on serum leptin concentrations in man. *Eur J Endocrinol* 135: 663-665, 1996.
8. **Blüher M, Brennan AM, Kelesidis T, Kratzsch J, Fasshauer M, Kralisch S, Williams CJ, and Mantzoros CS.** Total and high-molecular weight adiponectin in relation to metabolic variables at baseline and in response to an exercise treatment program: comparative evaluation of three assays. *Diabetes Care* 30: 280-285, 2007.
9. **Blüher M, Bullen JW, Lee JH, Kralisch S, Fasshauer M, Klötting N, Niebauer J, Schön MR, Williams CJ, and Mantzoros CS.** Circulating adiponectin and expression of adiponectin receptors in human skeletal muscle: Associations with metabolic parameters and insulin resistance and regulation by physical training. *J Clin Endocrinol Metab* 91: 2310-2316, 2006.
10. **Bobbert T, Wegewitz U, Brechtel L, Freudenberg M, Mai K, Möhlig M, Diederich S, Ristow M, Rochlitz H, Pfeiffer A, and Spranger J.** Adiponectin oligomers in human serum during acute and chronic exercise: relation to lipid metabolism and insulin sensitivity. *Int J Sports Med* 28: 2007.

11. **Bouassida A, Chamari K, Zaouali M, Feki Y, Zbidi A, and Tabka Z.** Review on leptin and adiponectin responses and adaptations to acute and chronic exercise. *Br J Sports Med* 44: 620-630, 2008.
12. **Boulé NG, Weisnagel SJ, Lakka TA, Tremblay A, Bergman R, Rankinen T, Leon A, Skinner J, Wilmore J, Rao D, and Bouchard C.** Effects of exercise training on glucose homeostasis: the HERITAGE Family Study. *Diabetes Care* 28: 108-114, 2005.
13. **Chandran M, Phillips SA, Ciaraldi T, and Henry RR.** Adiponectin: more than just another fat cell hormone. *Diabetes Care* 26: 2442-2450, 2003.
14. **Christiansen T, Paulsen SK, Bruun JM, Ploug T, Pedersen SB, and Richelsen B.** Diet-induced weight loss and exercise alone and in combination enhance the expression of adiponectin receptors in adipose tissue and skeletal muscle, but only diet-induced weight loss enhanced circulating adiponectin. *J Clin Endocrinol Metab* 95: 911-919, 2010.
15. **Dallongeville J, Cottel D, Ferrières J, Arveiler D, Bingham A, Ruidavets JB, Haas B, Ducimetière P, and Amouyel P.** Household income is associated with the risk of metabolic syndrome in a sex-specific manner. *Diabetes Care* 28: 409-515, 2005.
16. **Deepa M, Farooq S, Datta M, Deepa R, and Mohan V.** Prevalence of metabolic syndrome using WHO, ATP III and IDF definitions in Asian Indians: the Chennai Urban Rural Epidemiology Study (CURES-34). *Diabetes Metab Res Rev* 23: 127-134, 2007.
17. **Dekker JM, Girman C, Rhodes T, Nijpels G, Stehouwer CD, Bouter LM, and Heine RJ.** Metabolic syndrome and 10-year cardiovascular disease risk in the Hoorn Study. *Circulation* 112: 666-673, 2005.
18. **Després JP, and Lemieux I.** Abdominal obesity and metabolic syndrome. *Nature* 14: 881-887, 2006.
19. **Dill DB, and Costill DL.** Calculation of percentage changes in volumes of blood, plasma, and red cells in dehydration. *J Appl Physiol* 37: 247-248, 1974.
20. **Durstine JL, Grandjean PW, Cox CA, and Thompson PD.** Lipids, lipoproteins, and exercise. *J Cardiopulm Rehabil* 22: 385-398, 2002.
21. **Dyck DJ, Heigenhauser GJ, and Bruce CR.** The role of adipokines as regulators of skeletal muscle fatty acid metabolism and insulin sensitivity. *Acta Physiol* 186: 5-16, 2006.
22. **Elias AN, Pandian MR, Wang L, Suarez E, James N, and Wilson AF.** Leptin and IGF-I levels in unconditioned male volunteers after short-term exercise. *Psychoneuroendocrinology* 25: 453-461, 2000.
23. **Essig DA, Alderson NL, Ferguson MA, Bartoli WP, and Durstine JL.** Delayed effects of exercise on the plasma leptin concentration. *Metabolism* 49: 395-399, 2000.
24. **Fasshauer M, Klein J, Neumann S, Eszlinger M, and Paschke R.** Adiponectin gene expression is inhibited by beta-adrenergic stimulation via protein kinase A in 3T3-L1 adipocytes. *FEBS Lett* 507: 142-146, 2001.

25. **Fasshauer M, Klein J, Neumann S, Eszlinger M, and Paschke R.** Hormonal regulation of adiponectin gene expression in 3T3-L1 adipocytes. *Biochem Biophys Res Commun* 290: 1084-1089, 2002.
26. **Fergusson MA, White LJ, McCoy S, Kim HW, Petty T, and Wilsey J.** Plasma adiponectin response to acute exercise in healthy subjects. *Eur J Appl Physiol* 91: 324-329, 2004.
27. **Fisher JS, Van P, Zinder O, Landt M, and Kohrt WM.** Acute exercise effect on postabsorptive serum leptin. *J Appl Physiol* 91: 680-686, 2001.
28. **Flores MB, Fernandes MF, Ropelle ER, Faria MC, Ueno M, Velloso LA, Saad MJ, and Carnevalheira JB.** Exercise improves insulin and leptin sensitivity in hypothalamus of Wistar rats. *Diabetes* 55: 2554-2561, 2006.
29. **Ford ES, Giles WH, and Dietz WH.** Prevalence of the metabolic syndrome among US adults: Findings from the third National Health and Nutrition Examination Survey *JAMA* 287: 356-359, 2002.
30. **Ford ES, Giles WH, and Mokdad AH.** Increasing prevalence of the metabolic syndrome among U.S. Adults. *Diabetes Care* 27: 2444-2449, 2004.
31. **Franks PW, Brage S, Luan J, Ekelund U, Rahman M, Farooqi I, Halsall I, O'Rahilly S, and Wareham NJ.** Leptin predicts a worsening of the features of the metabolic syndrome independently of obesity. *Obes Res* 13: 1476-1486, 2005.
32. **Friedman JM.** Leptin at 14 y of age: An ongoing story. *Am J Clin Nutr* 89: 973S-979S, 2009.
33. **Friedman JM, and Halaas JL.** Leptin and the regulation of body weight in mammals. *Nature* 395: 763-770, 1998.
34. **Galbo H.** The hormonal responses to exercise. *Proc Nutr Soc* 44: 257-266, 1985.
35. **Gesta S, Tseng YH, and Kahn CR.** Developmental origin of fat: tracking obesity to its source. *Cell* 131: 242-256, 2007.
36. **Ghanassia E, Brun JF, Mercier J, and Raynaud E.** Oxidative mechanisms at rest and during exercise. *Clin Chim Acta* 383: 1-20, 2007.
37. **Grandjean PW, Alhassan S, and Goodlett M.** Post-heparin plasma lipase activity responses to daily exercise in hyperlipidemic men *Med Sci Sports Exerc* 34: 521, 2002.
38. **Grundy SM.** Metabolic syndrome pandemic. *Arterioscler Thromb Vasc Biol* 28: 629-636, 2008.
39. **Grundy SM.** Obesity, metabolic syndrome, and cardiovascular disease. *J Clin Endocrinol Metab* 89: 2595-2600, 2004.



40. **Grundy SM, Cleeman JI, Daniels SR, Donato KA, Eckel RH, Franklin BA, Gordon DJ, Krauss RM, Savage PJ, Smith SC, Spertus JA, and Costas F.** Diagnosis and management of the metabolic syndrome. An American Heart Association /National Heart, Lung, and Blood Institute Scientific Statement *Circulation* 112: 2735-2752, 2005.
41. **Guerre-Millo M, Gervois P, Raspé E, Madsen L, Poulain P, Derudas B, Herbert JM, Winegar DA, Willson TM, Fruchart JC, Berge RK, and Staels B.** Peroxisome proliferator-activated receptor alpha activators improve insulin sensitivity and reduce adiposity. *J Biol Chem* 275: 16638-16642, 2000.
42. **Gustat J, Srinivasan SR, Elkasabany A, and Berenson GS.** Relation of self-rated measures of physical activity to multiple risk factors of insulin resistance syndrome in young adults: The Bogalusa Heart Study. *J Clin Epidemiol* 55: 997-1006, 2002.
43. **Halle M, Berg A, Garwers U, Grathwohl D, Knisel W, and Keul J.** Concurrent reductions of serum leptin and lipids during weight loss in obese men with type II diabetes. *Am J Physiol* 277: E277-E282, 1999.
44. **Haluzík MM, and Haluzík M.** PPAR-alpha and insulin sensitivity. *Physiol Res* 55: 115-122, 2006.
45. **Hanley AJ, Carter AJ, Williams K, Festa A, D'Agostino RB, Wagenknecht LE, and Haffner SM.** Prediction of type 2 diabetes mellitus with alternative definitions of the metabolic syndrome: The Insulin Resistance Atherosclerosis Study *Circulation* 112: 3713-3721, 2005.
46. **Haskell WL, Lee IM, Pate RR, Powell KE, Blair SN, Franklin BA, Macera CA, Heath GW, Thompson PD, and Bauman A.** Physical activity and public health: updated recommendation for adults from the American College of Sports Medicine and the American Heart Association. *Med Sci Sports Exerc* 39: 1423-1434, 2007.
47. **Henriksen EJ.** Invited Review: Effects of acute exercise and exercise training on insulin resistance. *J Appl Physiol* 93: 788-796, 2002.
48. **Hickey MS, and Calsbeek DJ.** Plasma Leptin and Exercise: Recent Findings. *Sports Med* 31: 583-589, 2001.
49. **Hickey MS, Israel RG, and Gardiner SN.** Gender differences in serum leptin levels in humans *Biochem Mol Med* 59: 1-6, 1996.
50. **Hotta K, Funahashi T, Arita Y, Takahashi M, Matsuda M, Okamoto Y, Iwahashi H, Kuriyama H, Ouchi N, Maeda K, Nishida M, Kihara S, Sakai N, Nakajima T, Hasegawa K, Muraguchi M, Ohmoto Y, Nakamura T, Yamashita S, Hanafusa T, and Matsuzawa Y.** Plasma concentrations of a novel, adipose-specific protein, adiponectin, in type 2 diabetic patients *Arterioscler Thromb Vasc Biol* 20: 1599-2000, 2000.
51. **Houmard JA, Cox JH, MacLean PS, and Barakat HA.** Effect of short-term exercise training on leptin and insulin action. *Metabolism* 49: 858-861, 2000.

52. **Howlett KF, Sakamoto K, Yu H, Goodyear LJ, and Hargreaves M.** Insulin-stimulated insulin receptor substrate-2-associated phosphatidylinositol 3-kinase activity is enhanced in human skeletal muscle after exercise. *Metabolism* 55: 1046-1052, 2006.
53. **Hsieh CJ, and Wang PW.** Effectiveness of weight loss in the elderly with type 2 diabetes mellitus. *J Endocrinol Invest* 28: 973-977, 2005.
54. **Hulthe J, Hulthen LM, and Fagerberg B.** Low adipocyte-derived plasma protein adiponectin concentrations are associated with the metabolic syndrome and small dense low-density lipoprotein particles: Atherosclerosis and Insulin Resistance Study. *Metabolism* 52: 1612-1614, 2003.
55. **Hulver MW, and Houmard JA.** Plasma Leptin and Exercise: Recent Findings. *Sports Med* 33: 473-482, 2003.
56. **Hulver MW, Zheng D, Tanner CJ, Houmard JA, Kraus WE, Slentz CA, Sinha MK, Pories WJ, MacDonald KG, and Dohm GL.** Adiponectin is not altered with exercise training despite enhanced insulin action. *Am J Physiol Endocrinol Metab* 283 283: E861-E865, 2002.
57. **Inadera H.** The usefulness of circulating adipokine levels for the assessment of obesity-related health problems. *Int J Med Sci* 5: 248-262, 2008.
58. **Ishii T, Yamakita T, Yamagami K, Yamamoto T, Miyamoto M, Kawasaki K, Hosoi M, Yoshioka K, Sato T, Tanaka S, and Fujii S.** Effect of Exercise Training on Serum Leptin Levels in Type 2 Diabetic Patients. *Metabolism* 50: 1136-1140, 2001.
59. **Jamurtas AZ, Theocharis V, Koukoulis G, Stakias N, Fatouros IG, Kouretas D, and Kotedakis Y.** The effects of acute exercise on serum adiponectin and resistin levels and their relation to insulin sensitivity in overweight males. *Eur J Appl Physiol* 97: 122-126, 2006.
60. **Jensen TE, Wojtaszewski JF, and Richter EA.** AMP-activated protein kinase in contraction regulation of skeletal muscle metabolism: Necessary and/or sufficient? *Acta Physiol* 196: 155-174, 2009.
61. **Jessen N, and Goodyear LJ.** Contraction signaling to glucose transport in skeletal muscle *J Appl Physiol* 99: 330-337, 2005.
62. **Jürimäe J, and Jürimäe T.** Leptin responses to short term exercise in college level male rowers. *Br J Sports Med* 39: 6-9, 2005.
63. **Jürimäe J, Purge P, and Jürimäe T.** Adiponectin and stress hormone responses to maximal sculling after volume-extended training season in elite rowers. *Metabolism* 55: 13-19, 2006.
64. **Jürimäe J, Purge P, and Jürimäe T.** Adiponectin is altered after maximal exercise in highly trained male rowers. *Eur J Appl Physiol* 93: 502-505, 2005.
65. **Kadowaki T, and Yamauchi T.** Adiponectin and adiponectin receptors. *Endocr Rev* 26: 439-451, 2005.

66. **Kelesidis I, Kelesidis T, and Mantzoros CS.** Adiponectin and cancer: a systematic review. *Br J Cancer* 94: 1221-1225, 2006.
67. **Kershaw EE, and Flier JS.** Adipose tissue as an endocrine organ. *J Clin Endocrinol Metab* 89: 2548-2556, 2004.
68. **Kim MJ, Maachi M, Debard C, Loizon E, Clément K, Bruckert E, Hainque B, Capeau J, Vidal H, and Bastard JP.** Increased adiponectin receptor-1 expression in adipose tissue of impaired glucose-tolerant obese subjects during weight loss *European Journal of Endocrinology* 155: 2006.
69. **Kjaer M, Christensen NJ, Sonne B, Richter EA, and Galbo H.** Effect of exercise on epinephrine turnover in trained and untrained male subjects. *J Appl Physiol* 59: 1061-1067, 1985.
70. **Komura N, Kihara S, Sonoda M, Kumada M, Fujita K, Hiuge A, Okada T, Nakagawa Y, Tamba S, Kuroda Y, Hayashi N, Sumitsuji S, Kawamoto T, Matsumoto S, Ouchi N, Arita Y, Okamoto Y, Shimomura I, Funahashi T, and Matsuzawa Y.** Clinical significance of high-molecular weight form of adiponectin in male patients with coronary artery disease. *Circ J* 72: 23-28, 2008.
71. **Kondo T, Kobayashi I, and Murakami M.** Effect of exercise on circulating adipokine levels in obese young women. *Endocr J* 53: 189-195, 2006.
72. **Kraemer RR, Aboudehen KS, Carruth AK, Durand RJ, Acevedo EO, Hebert EP, Johnson LG, and Castracane VD.** Adiponectin responses to continuous and progressively intense intermittent exercise *Med Sci Sports Exerc* 35: 1320-1325, 2003.
73. **Kraemer RR, Chu H, and Castracane VD.** Leptin and Exercise. *Exp Biol Med* 227: 701-708, 2002.
74. **Kriketos AD, Gan SK, Poynten AM, Furler SM, Chisholm DJ, and Campbell LV.** Exercise increases adiponectin levels and insulin sensitivity in humans. *Diabetes Care* 27: 629-630, 2004.
75. **Kyriazis GA, Caplan JD, Lowndes J, Carpenter RL, Dennis KE, Sivo SA, and Angelopoulos TJ.** Moderate exercise-induced energy expenditure does not alter leptin levels in sedentary obese men. *Clin J Sport Med* 17: 49-51, 2007.
76. **Lakka HM, Laaksonen DE, Lakka TA, Niskanen NK, Kumpusalo E, Tuomilehto J, and Salonen JT.** The metabolic syndrome and total and cardiovascular disease mortality in middle-aged men. *JAMA* 288: 2709-2716, 2002.
77. **Lakka TA, Laaksonen DE, Lakka HM, Mannikko LK, Rauramaa R, and Salonen JT.** Sedentary Lifestyle, Poor Cardiorespiratory Fitness, and the Metabolic Syndrome. *Med Sci Sports Exerc* 35: 1279-1286, 2003.
78. **LaMonte MJ, Barlow CE, Jurca R, Kampert JB, Church TS, and Blair SN.** Cardiorespiratory Fitness Is Inversely Associated With the Incidence of Metabolic Syndrome: A Prospective Study of Men and Women. *Circulation* 112: 505-512, 2005.

79. **Landt M, Lawson GM, Helgeson JM, Davila-Roman VG, Ladenson JH, Jaffe AS, and Hickner RC.** Prolonged exercise decreases serum leptin concentrations. *Metabolism* 46: 1109-1112, 1997.
80. **Lara-Castro C, Luo N, Wallace P, Klein RL, and Garvey WT.** Adiponectin multimeric complexes and the metabolic syndrome trait cluster. *Diabetes* 55: 249-259, 2006.
81. **Leal-Cerro A, Garcia-Luna PP, Astorga R, Parejo J, Peino R, Dieguez C, and Casanueva FF.** Serum leptin levels in male marathon athletes before and after the marathon run. *J Clin Endocrinol Metab* 83: 2376-2379, 1998.
82. **Lee YH, and Pratley RE.** Abdominal obesity and cardiovascular disease risk: The emerging role of the adipocyte. *JCRP* 27: 2-10, 2007.
83. **Lee YS.** The Role of Leptin-Melanocortin System and Human Weight Regulation: Lessons from Experiments of Nature. *Ann Acad Med Singapore* 38: 34-44, 2009.
84. **Loffreda S, Yang SQ, Lin HZ, Karp CL, Brengman ML, Wang DJ, Klein AS, Bulkley GB, Bao C, Noble PW, Lane MD, and Diehl AM.** Leptin regulates proinflammatory immune responses. *FASEB J* 12: 57-65, 1998.
85. **Lopes RH, Reid I, and Hobson PR.** The two-dimensional Kolmogorov-Smirnov test *XI International Workshop on Advanced Computing and Analysis Techniques in Physics Research, Amsterdam, the Netherlands* April: 23-27, 2007.
86. **Lorenzo C, Okoloise M, Williams K, Stern MP, and Haffner SM.** The metabolic syndrome as predictor of type 2 diabetes: The San Antonio Heart Study. *Diabetes Care* 26: 3153-3159, 2003.
87. **Lorenzo C, Williams K, Gonzalez-Villalpando C, and Haffner SM.** The prevalence of the metabolic syndrome did not increase in Mexico City between 1990-1992 and 1997-1999 despite more central obesity. *Diabetes Care* 28: 2480-2485, 2005.
88. **Maffei M, Halaas J, Ravussin E, Pratley RE, Lee GH, Zhang Y, Fei H, Kim S, Lallone R, Ranganathan S, Kern PA, and Friedman JM.** Leptin levels in human and rodent: measurement of plasma leptin and ob RNA in obese and weight-reduced subjects. *Nat Med* 1: 1155-1161, 1995.
89. **Matsuzawa Y.** Adiponectin: Identification, physiology and clinical relevance in metabolic and vascular disease. *Atheroscler Suppl* 6: 7-14, 2005.
90. **Matthews DR, Hosker JP, Rudenski AS, Naylor BA, Treacher DF, and Turner RC.** Homeostasis model assessment: insulin resistance and beta-cell function from fasting plasma glucose and insulin concentrations in man. *Diabetologia* 28: 412-419, 1985.
91. **McLaughlin T, Allison G, Abbasi F, Lamendola C, and Reaven G.** Prevalence of insulin resistance and associated cardiovascular disease risks factors among normal weight, overweight and obese individuals *Metabolism* 53: 495-499, 2004.

92. **McMurray RG, and Hackney AC.** Interactions of Metabolic Hormones, Adipose Tissue and Exercise. *Sports Med* 35: 393-412, 2005.
93. **Melby C, and Hickey MS.** Energy Balance and Body Weight Regulation. *Sports Science Exchange* 99: 2005.
94. **Minokoshi Y, Kim YB, Peroni OD, Fryer LG, Müller C, Carling D, and Kahn BB.** Leptin stimulates fatty-acid oxidation by activating AMP-activated protein kinase. *Nature* 415: 2002.
95. **Nassis GP, Papantakou K, Skenderi K, Triandafillopoulou M, Kavouras SA, Yannakoulia M, Chrousos GP, and Sidossis LS.** Aerobic exercise training improves insulin sensitivity without changes in body weight, body fat, adiponectin, and inflammatory markers in overweight and obese girls *Metabolism* 54: 1472-1479, 2005.
96. **NCEP.** Executive summary of the Third Report of the National Cholesterol Education Program (NCEP) expert panel on detection, evaluation, and treatment of high blood cholesterol in adults (Adult Treatment Panel III). *JAMA* 285: 2486-2496, 2001.
97. **Noland RC, Baker JT, Boudreau SR, Kobe RW, Tanner CJ, Hickner RC, McCammon MR, and Houmard JA.** Effect of intense training on training on plasma leptin in male and female swimmers. *Med Sci Sports Exerc* 33: 227-231, 2001.
98. **Numao S, Suzuki M, Matsuo T, Nomata Y, Nakata Y, and Tanaka K.** Effects of acute aerobic exercise on high-molecular-weight adiponectin. *Med Sci Sports Exerc* 40: 1271-1276, 2008.
99. **O'Leary VB, Jorett AE, Marchetti CM, Gonzalez F, Phillips SA, Ciaraldi TP, and Kirwan JP.** Enhanced adiponectin multimer ratio and skeletal muscle adiponectin receptor expression following exercise training and diet in older insulin resistant adults. *Am J Physiol Endocrinol Metab* 293: E421-E427, 2007.
100. **O'Leary VB, Marchetti CM, Krishnan RK, Stetzer BP, Gonzalez F, and Kirwan JP.** Exercise-induced reversal of insulin resistance in obese elderly is associated with reduced visceral fat *J Appl Physiol* 100: 1584-1589, 2006.
101. **Oberbach A, Tönjes A, Klötting N, Fasshauer M, Kratzsch J, Busse MW, Paschke R, Stumvoll M, and Blüher M.** Effect of a 4 week physical training program on plasma concentrations of inflammatory markers in patients with abnormal glucose tolerance. *Eur J Endocrinol* 154: 577-585, 2006.
102. **Ouchi N, Kihara S, Arita Y, Maeda K, Kuriyama H, Okamoto Y, Hotta K, Nishida M, Takahashi M, Nakamura T, Yamashita S, Funahashi T, and Matsuzawa Y.** Novel modulator for endothelial adhesion molecules: adipocyte-derived plasma protein adiponectin. *Circulation* 100: 2473-2476, 1999.

103. **Pajvani UB, Du X, Combs TP, Berg AH, Rajala MW, Schulthess T, Engel J, Brownlee M, and Scherer PE.** Structure-function studies of the adipocyte-secreted hormone Acrp30/adiponectin implications for metabolic regulation and bioactivity. *J Biol Chem* 278: 9073-9085, 2002.
104. **Pajvani UB, Hawkins M, Combs TP, Rajala MW, Doebber T, Berger JP, Wagner JA, Wu M, Knopps A, Xiang AH, Utzschneider KM, Kahn SE, Olefsky JM, Buchanan TA, and Scherer PE.** Complex distribution, not absolute amount of adiponectin, correlates with thiazolidinedione-mediated improvement in insulin sensitivity. *J Biol Chem* 279: 12152-12162, 2004.
105. **Park YW, Zhu S, Palaniappan L, Heshka S, Carnethon MR, and Heymsfield SB.** The metabolic syndrome: Prevalence and associated risk factor findings in the US population from the third National Health and Nutrition Examination Survey, 1988-1994. *Arch Intern Med* 163: 427-436, 2003.
106. **Pasman WJ, Westerterp-Plantenga MS, and Saris WH.** The effect of exercise training on leptin levels in obese males. *Am J Physiol Endocrinol Metab* 274: 280-286, 1998.
107. **Perusse L, Collier G, Gagnon J, Leon AS, Rao DC, Skinner JS, Wilmore JH, Nadeau A, Zimmet PZ, and Bouchard C.** Acute and chronic effects of exercise on leptin levels in humans. *J Appl Physiol* 83: 5-10, 1997.
108. **Polak J, Klimcakova E, Moro C, Viguerie N, Berlan M, Hejnova J, Richterova B, Kraus I, Langin D, and Stich V.** Effect of aerobic training on plasma levels and subcutaneous abdominal adipose tissue gene expression of adiponectin, leptin, interleukin 6, and tumor necrosis factor alpha in obese women. *Metabolism* 55: 1375-1381, 2006.
109. **Punyadeera C, Zorenc AH, and Koopman R.** The effects of exercise and adipose tissue lipolysis on plasma adiponectin concentration and adiponectin receptor expression in human skeletal muscle. *Eur J Endocrinol* 152: 427-436, 2005.
110. **Reseland JE, Anderssen SA, Solvoll K, Hjermann I, Urdal P, Holme I, and Drevon CA.** Effect of long-term changes in diet and exercise on plasma leptin concentrations. *Am J Clin Nutr* 73: 240-245, 2001.
111. **Richter EA, Nielsen JN, Jørgensen SB, Frøsig C, Birk JB, and Wojtaszewski JF.** Exercise signalling to glucose transport in skeletal muscle. *Proc Nutr Soc* 63: 211-216, 2004.
112. **Ring-Dimitriou S, Paulweber B, von Duvillard SP, Stadlmann M, LeMura LM, Lang J, and Müller E.** The effect of physical activity and physical fitness on plasma adiponectin in adults with predisposition to metabolic syndrome. *Eur J Appl Physiol* 98: 472-481, 2006.
113. **Röckl KS, Witzak CA, and Goodyear LJ.** Signaling mechanisms in skeletal muscle: acute responses and chronic adaptations to exercise. *IUBMB Life* 60: 145-153, 2008.

114. **Rokling-Andersen MH, Reseland JE, Veierød MB, Anderssen SA, Jacobs DRJ, Urdal P, Jansson JO, and Drevon CA.** Effects of long-term exercise and diet intervention on plasma adipokine concentrations. *Am J Clin Nutr* 86: 1293-1301, 2007.
115. **Ronti T, Lupattelli G, and Mannarino E.** The endocrine function of adipose tissue: An update. *Clin Endocrinol* 64: 355-365, 2006.
116. **Ryan AS, Nicklas BJ, Berman DM, and Elahi D.** Adiponectin levels do not change with moderate dietary-induced weight loss and exercise in obese postmenopausal women *Int J Obes Relat Metab Disord* 27: 1066-1071, 2003.
117. **Scarpace PJ, Matheny M, Zhang Y, Shek WE, Prima V, Zolotukhin S, and Tumer N.** Leptin-Induced Leptin Resistance Reveals Separate Roles for the Anorexic and Thermogenic Responses in Weight Maintenance. *Endocrinology* 143: 3026–3035, 2002.
118. **Scherer PE, Williams S, Fogliano M, Baldini G, and Lodish HF.** A novel protein similar to C1q produced exclusively in the adipocytes *J Biol Chem* 270: 26746-26749, 1995.
119. **Shibata R, Ouchi N, and Murohara T.** Adiponectin and Cardiovascular Disease. *Circ J* 3: 608-614, 2009.
120. **Shin MS, Kim H, Chang HK, Lee TH, Jang MH, Shin MC, Lim BV, Lee HH, Kim YP, Yoon JH, Jeong IG, and Kim CJ.** Treadmill exercise suppresses diabetes-induced increment of neuropeptide Y expression in the hypothalamus of rats. *Neurosci Lett* 346: 157-160, 2003.
121. **Simpson KA, and Singh MA.** Effects of exercise on adiponectin: A systematic review. *Obesity* 16: 241-256, 2008.
122. **St-Pierre DH, Faraj M, and Karelis AD.** Lifestyle behaviours and components of energy balance as independent predictors of ghrelin and adiponectin in young non-obese women. *Diabetes Metab* 32: 131-139, 2006.
123. **Steinberg GR, Rush JW, and Dyck DJ.** AMPK expression and phosphorylation are increased in rodent muscle after chronic leptin treatment. *Am J Physiol Endocrinol Metab* 284: E648-654, 2003.
124. **Thompson PD, Crouse SF, Goodpaster B, Kelley D, Moyna N, and Pescatello L.** The acute versus the chronic response to exercise. *Med Sci Sports Exerc* 33: S438-445, 2001.
125. **Thong FS, Hudson R, Ross RI, Janssen I, and Graham TE.** Plasma leptin in moderately obese men: Independent effects of weight loss and aerobic exercise. *Am J Physiol Endocrinol Metab* 279: E307-E313, 2000.
126. **Torjman MC, Zafeiridis A, Paolone AM, Wilkerson C, and Considine RV.** Serum leptin during recovery following maximal incremental and prolonged exercise. *Int J Sports Med* 20: 444-450, 1999.

127. **Tsuchida A, Yamauchi T, Ito Y, Hada Y, Maki T, Takekawa S, Kamon J, Kobayashi M, Suzuki R, Hara K, Kubota N, Terauchi Y, Froguel P, Nakae J, Kasuga M, Accili D, Tobe K, Ueki K, Nagai R, and Kadowaki T.** Insulin/Foxo1 pathway regulates expression levels of adiponectin receptors and adiponectin sensitivity. *J Biol Chem* 279: 30817-30822, 2004.
128. **Tsukinoki R, Morimoto K, and Nakayama K.** Association between lifestyle factors and plasma adiponectin levels in Japanese men. *Lipids Health Dis* 4: 27, 2005.
129. **Tuominen JA, Ebeling P, Laquier FW, Heiman ML, Stephens T, and Koivisto VA.** Serum leptin concentration and fuel homeostasis in healthy man. *Eur J Clin Invest* 27: 206-211, 1997.
130. **Turkoglu C, Duman BS, Gunay D, Cagatay P, Ozcan R, and Buyukadevrin AS.** Effect of abdominal obesity on insulin resistance and components of the metabolic syndrome: Evidence supporting obesity as the central feature. *Obesity Surgery* 13: 699-705, 2003.
131. **Vettor R, De Pergola G, Pagano C, Englaro P, Laudadio E, Giorgino F, Blum WF, Giorgino R, and Federspil G.** Gender differences in serum leptin in obese people: relationships with testosterone, body fat distribution and insulin sensitivity. *Eur J Clin Invest* 27: 1016-1024, 1997.
132. **Vu V, Riddell MC, and Sweeney G.** Circulating adiponectin and adiponectin receptor expression in skeletal muscle: effects of exercise. *Diabetes Metab Res Rev* 23: 600-611, 2007.
133. **Waki H, Yamauchi T, Kamon J, Ito Y, Uchida S, Kita S, Hara K, Hada Y, Vasseur F, Froguel P, Kimura S, Nagai R, and Kadowaki T.** Impaired multimerization of human adiponectin mutants associated with diabetes. *J Biol Chem* 278: 40352-40363, 2003.
134. **Weltman A, Pritzlaff CJ, Wideman L, Considine RV, Fryburg DA, Gutgesell ME, Hartman ML, and Veldhuis JD.** Intensity of acute exercise does not affect serum leptin concentrations in young men. *Med Sci Sports Exerc* 32: 1556-1561, 2000.
135. **Weyer C, Funahashi T, Tanaka S, Hotta K, Matzuzawa J, Pratley RE, and Tataranni PA.** Hypoadiponectinemia in obesity and type 2 diabetes: Close association with insulin resistance and hyperinsulinemia. *J Clin Endocrinol Metab* 86: 1930-1935, 2001.
136. **Witczak CA, Fujii N, Hirshman MF, and Goodyear LJ.** Ca<sup>2+</sup>/calmodulin-dependent protein kinase kinase-alpha regulates skeletal muscle glucose uptake independent of AMP-activated protein kinase and Akt activation. *Diabetes* 56: 1403-1409, 2007.
137. **Wojtaszewski JF, Nielsen JN, and Richter EA.** Exercise Effects on Muscle Insulin Signaling and Action. Invited Review: Effect of acute exercise on insulin signaling and action in humans. *J Appl Physiol* 93: 384-392, 2002.
138. **Xu A, Wong LC, Wang Y, Xu JY, Cooper GJ, and Lam KS.** Chronic treatment with growth hormone stimulates adiponectin gene expression in 3T3-L1 adipocytes. *FEBS Lett* 572: 129-134, 2004.



139. **Yamauchi T, Kamon J, Ito Y, Tsuchida A, Yokomizo T, Kita S, Sugiyama T, Miyagishi M, Hara K, Tsunoda M, Murakami K, Ohteki T, Uchida S, Takekawa S, Waki H, Tsuno NH, Shibata Y, Terauchi Y, Froguel P, Tobe K, Koyasu S, Taira K, Kitamura T, Shimizu T, Nagai R, and Kadowaki T.** Cloning of adiponectin receptors that mediate antidiabetic metabolic effects. *Nature* 12: 762-769, 2003.
140. **Yamauchi T, Kamon J, Minokoshi Y, Ito Y, Waki H, Uchida S, Yamashita S, Noda M, Kita S, Ueki K, Eto K, Akanuma Y, Froguel P, Foufelle F, Ferre P, Carling D, Kimura S, Nagai R, Kahn BB, and Kadowaki T.** Adiponectin stimulates glucose utilization and fatty-acid oxidation by activating AMP-activated protein kinase. *Nat Med* 8: 1288-1295, 2002.
141. **Yamauchi T, Kamon J, Waki H, Terauchi Y, Kubota N, Hara K, Mori Y, Ide T, Murakami K, Tsuboyama-Kasaoka N, Ezaki O, Akanuma Y, Gavrilova O, Vinson C, Reitman ML, Kagechika H, Shudo K, Yoda M, Nakano Y, Tobe K, Nagai R, Kimura S, Tomita M, Froguel P, and Kadowaki T.** The fat-derived hormone adiponectin reverses insulin resistance associated with both lipodystrophy and obesity. *Nat Med* 7: 941-946, 2001.
142. **Yatagai T, Nishida Y, Nagasaka S, Nakamura T, Tokuyama K, Shindo M, Tanaka H, and Ishibashi S.** Relationship between exercise training-induced increased in insulin sensitivity and adiponectinemia in healthy men. *Endocr J* 50: 233-238, 2003.
143. **Yokoyama H, Hirose H, Ohgo H, and Saito I.** Associations among lifestyle status, serum adiponectin level and insulin resistance. *Intern Med* 43: 453-457, 2004.
144. **You T, Nicklas BJ, Ding J, Penninx BW, Goodpaster BH, Bauer DC, Tylavsky FA, Harris TB, and Kritchevsky SB.** The metabolic syndrome is associated with circulating adipokines in older adults across a wide range of adiposity. *J Gerontol* 63: 414-419, 2008.
145. **Zhu W, Cheng KY, Vanhoutte PM, Lam KS, and Xu A.** Vascular effects of adiponectin: Molecular mechanism and potential therapeutic intervention *Clinical Science* 114: 361-374, 2008.
146. **Ziemke F, and Mantzoros CS.** Adiponectin in insulin resistance: lessons from translational research. *Am J Clin Nutr* 91: 258S-261S, 2010.
147. **Zierath JR.** Exercise Effects of Muscle Insulin Signaling and Action. Invited Review: Exercise training-induced changes in insulin signaling in skeletal muscle. *J Appl Physiol* 93: 773-781, 2002.